

Fractional quantum Hall effect in a quantum point contact at filling fraction $5/2$

J. B. Miller,¹ I. P. Radu,² D. M. Zumbühl,^{2,3} E. M. Levenson-Falk,⁴
M. A. Kastner,² C. M. Marcus,⁴ L. N. Pfeiffer,⁵ and K. W. West⁵

¹*Division of Engineering and Applied Science, Harvard University, Cambridge, Massachusetts 02138*

²*Department of Physics, Massachusetts Institute of Technology, Cambridge, Massachusetts 02139*

³*Department of Physics and Astronomy, University of Basel, Klingelbergstrasse 82, CH-4056 Basel, Switzerland*

⁴*Department of Physics, Harvard University, Cambridge, Massachusetts 02138*

⁵*Bell Labs, Lucent Technologies, Murray Hill, New Jersey 07974*

(Dated: September 10, 2018)

Recent theories suggest that the excitations of certain quantum Hall states may have exotic braiding statistics which could be used to build topological quantum gates. This has prompted an experimental push to study such states using confined geometries where the statistics can be tested. We study the transport properties of quantum point contacts (QPCs) fabricated on a GaAs/AlGaAs two dimensional electron gas that exhibits well-developed fractional quantum Hall effect, including at bulk filling fraction $\nu_{\text{bulk}} = 5/2$. We find that a plateau at effective filling factor $\nu_{\text{QPC}} = 5/2$ is identifiable in point contacts with lithographic widths of $1.2\ \mu\text{m}$ and $0.8\ \mu\text{m}$, but not $0.5\ \mu\text{m}$. We study the temperature and dc-current-bias dependence of the $\nu_{\text{QPC}} = 5/2$ plateau as well as neighboring fractional and integer plateaus in the QPC while keeping the bulk at $\nu_{\text{bulk}} = 3$. Transport near $\nu_{\text{QPC}} = 5/2$ in the QPCs is consistent with a picture of chiral Luttinger liquid edge-states with inter-edge tunneling, suggesting that an incompressible state at $\nu_{\text{QPC}} = 5/2$ forms in this confined geometry.

The discovery [1] of a fractional quantum Hall effect (FQHE) at the even-denominator filling fraction $\nu = 5/2$ has sparked a series of experimental [2, 3, 4, 5, 6] and theoretical [7, 8, 9] studies, leading to a prevailing interpretation of the $5/2$ state as comprised of paired fermions condensed into a BCS-like state [10, 11, 12, 13]. Within this picture, excitations of the $5/2$ ground state possess nonabelian statistics [14, 15, 16] and associated topological properties. The possibility that such a topological state can be accessed in the laboratory has prompted recent theoretical work aimed at experimentally testing the nonabelian character of the $5/2$ state [17, 18, 19, 20, 21], and building topologically protected quantum gates controlled by manipulating the excitations of the $5/2$ state [22, 23, 24].

While proposed tests of the statistics of excitations of the $5/2$ state make use of confined (\sim few micron) geometries, previous studies of the $5/2$ state have been conducted in macroscopic ($100\ \mu\text{m} - 5\ \text{mm}$) samples. Although experiments using mesoscopic samples with a quantum point contact (QPC) are now routine, the $5/2$ state is exceptionally fragile; only the highest quality GaAs/AlGaAs heterostructures exhibit a $5/2$ state even in bulk samples. Experimental investigation of the statistics of the $5/2$ ground state is crucial, especially since alternative models have been proposed to explain the $5/2$ state in confined geometries [25] and in the bulk [12, 26].

In this paper we study the $5/2$ state in the vicinity of a quantum point contact. Near a QPC, the electron density is not uniform, so the notion of a QPC-filling fraction is not well defined. However, based on transport

measurements, it is possible to define an effective filling fraction in the vicinity of the QPC (ν_{QPC}), as discussed below. Below 30 mK, a plateau-like feature with diagonal resistance (also defined below) near, but above, the bulk quantized value of $0.4h/e^2$ is evident at $\nu_{\text{QPC}} = 5/2$ in QPCs with $1.2\ \mu\text{m}$ and $0.8\ \mu\text{m}$ spacings between the gates. On this plateau, we find a peak in the differential resistance at dc-current bias $I_{\text{dc}} = 0$ and a dip around

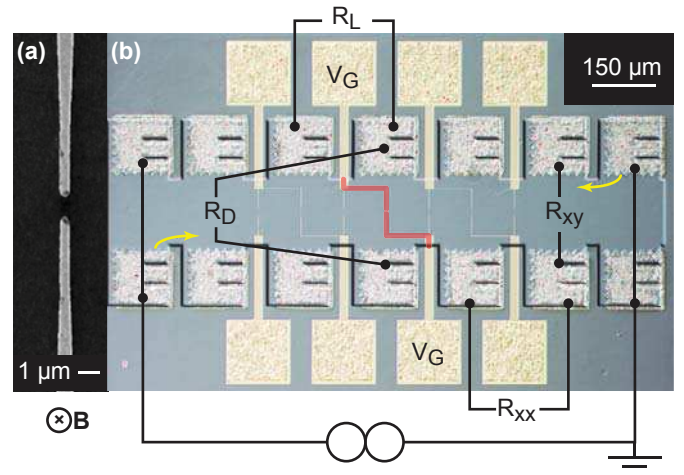

FIG. 1: Device and measurement setup. (a) SEM micrograph of the $0.5\ \mu\text{m}$ QPC. (b) Optical micrograph of the entire device (the outline of the wet-etched Hall bar has been enhanced for clarity). The measurement circuit for the red-highlighted QPC is drawn schematically, with the direction of the edge-current flow indicated by the yellow arrows.

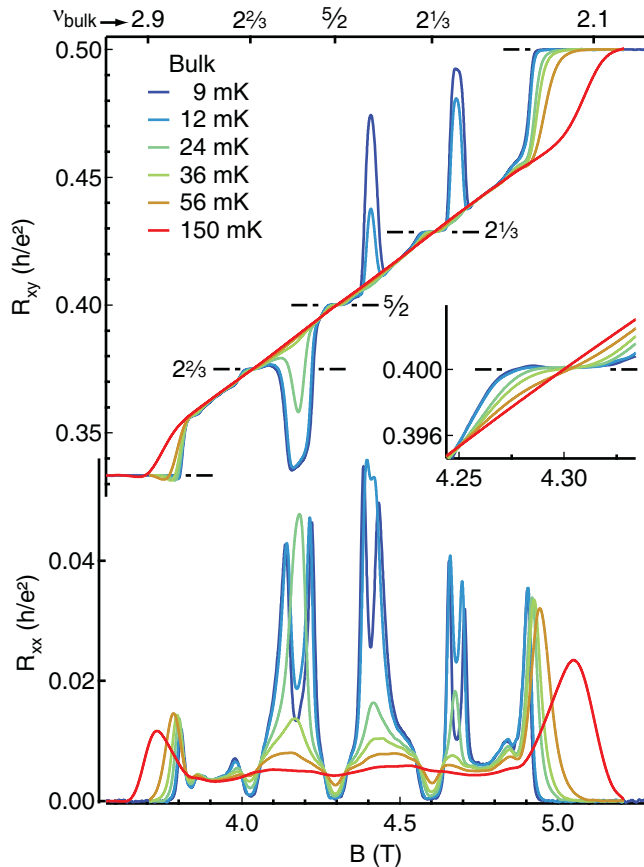

FIG. 2: Bulk transport measurements, including T dependence (T refers to the temperature of the refrigerator). The inset is an enlargement of the R_{xy} data near $\nu_{\text{bulk}} = 5/2$.

$I_{\text{dc}} \sim 1.2 \text{ nA}$, a characteristic shape that is consistent with QPC-induced quasiparticle tunneling between fractional edge states [27]. We also observe a zero-bias peak at $\nu_{\text{QPC}} = 21/3$, whereas we find a zero-bias dip near $\nu_{\text{QPC}} = 22/3$ (not shown), consistent with previous QPC studies for $\nu_{\text{QPC}} < 1$ [28]. As the temperature increases from 30 mK to 70 mK, the plateaus in the QPC disappear. Fractional plateaus are not observed in a $0.5 \mu\text{m}$ QPC, and the I_{dc} characteristic is flat for all magnetic fields. Together, these observations suggest that the $5/2$ state is destroyed in the $0.5 \mu\text{m}$ QPC, but can survive and exhibit quasiparticle tunneling [28, 29, 30] in the larger QPCs.

R_{xy} , R_{xx} , R_{D} and R_{L} (Fig. 1) are four-wire differential resistances ($R = dV/dI_{\text{ac}}$), measured at $I_{\text{dc}} = 0$ unless otherwise noted. In the IQHE regime, these resistances can be readily interpreted in terms of edge channels [31, 32], where N_{bulk} is the number of edge channels in the bulk and $N_{\text{QPC}} (\leq N_{\text{bulk}})$ is the number traversing the QPC. The bulk Hall resistance, $R_{xy} \sim h/e^2(1/N_{\text{bulk}})$, probes the number of edge states in the bulk region. In the absence of tunneling across the Hall bar $R_{xy} = h/e^2(1/N_{\text{bulk}})$. The bulk longitudinal resistance, R_{xx} ,

vanishes when R_{xy} shows a plateau. The diagonal resistance across a QPC, $R_{\text{D}} \sim h/e^2(1/N_{\text{QPC}})$, is sensitive only to the number of edge channels traversing the QPC, and hence provides a QPC-analog to the bulk R_{xy} . The longitudinal resistance across the QPC, $R_{\text{L}} \sim R_{\text{D}} - R_{xy}$, contains information about both the bulk and the QPC-region, and is not directly analogous to the bulk R_{xx} . On bulk IQHE plateaus, the filling fraction is equivalent to the number of edge states, $\nu_{\text{bulk}} = N_{\text{bulk}}$. By analogy, in the QPC, where the filling fraction is not well defined due to nonuniform density, we define an effective filling fraction in the QPC: $\nu_{\text{QPC}} \sim h/e^2(1/R_{\text{D}})$.

The edge state interpretation for R_{xy} , R_{xx} , R_{D} , and R_{L} has been extended to the FQHE [32, 33, 34, 35, 36, 37, 38, 39]. Within this generalized picture, a quantized plateau in $R_{xy} \sim h/e^2(1/\nu_{\text{bulk}})$ corresponds to the quantum Hall state at filling fraction ν_{bulk} , and a plateau in $R_{\text{D}} \sim h/e^2(1/\nu_{\text{QPC}})$ indicates that an incompressible quantum Hall state has formed in the vicinity of the QPC with effective filling fraction ν_{QPC} . We associate deviations from precisely quantized values with tunneling, which we study below as a function of temperature and bias.

To simplify the study of quantum states in the vicinity of the QPC, the perpendicular magnetic field (B) and gate voltage of the QPC (V_{g}) are tuned such that ν_{bulk} is fixed at an integer quantum Hall effect (IQHE) plateau whenever ν_{QPC} is at a value of interest. With $R_{xx} \sim 0$ and R_{xy} quantized to an IQHE plateau, features in R_{D} and R_{L} measurements can be attributed to the QPC region and not the bulk.

Previously, QPCs have been used to selectively transmit integer [40, 41] and fractional edge channels [36, 42], and to study inter-edge tunneling between fractional edge channels, including in the regime where the bulk is intentionally set to an IQHE plateau [28, 43]. Comparisons with these results are discussed below. QPCs have also been employed in studies of noise [44, 45] and (along with etched trenches) interference of quasiparticles [46] in the FQHE regime. In all of these studies $\nu < 2$, where the FQHE gaps are typically much larger than those with $\nu > 2$.

The sample is a GaAs/AlGaAs heterostructure grown in the [001] direction with electron gas layer 200 nm below the surface, with Si δ -doping layers 100 nm and 300 nm below the surface. A $150 \mu\text{m}$ -wide Hall bar is patterned using photolithography and a $\text{H}_2\text{O}:\text{H}_2\text{SO}_4:\text{H}_2\text{O}_2$ (240:8:1) wet-etch, followed by thermally evaporated Cr/Au (5 nm/15 nm) top-gates patterned using electron-beam lithography (see Fig. 1). The gates form QPCs with lithographic separation between gates of 0.5, 0.8 and $1.2 \mu\text{m}$. Depleting the electron gas beneath only one side of a QPC has no effect on transport measurements. Gate voltages were restricted to the range -1.9 V (depletion) to -3 V and were allowed to stabilize for several hours at each setpoint before measuring; beyond -3 V the conductance was typically hysteretic as a function of gate

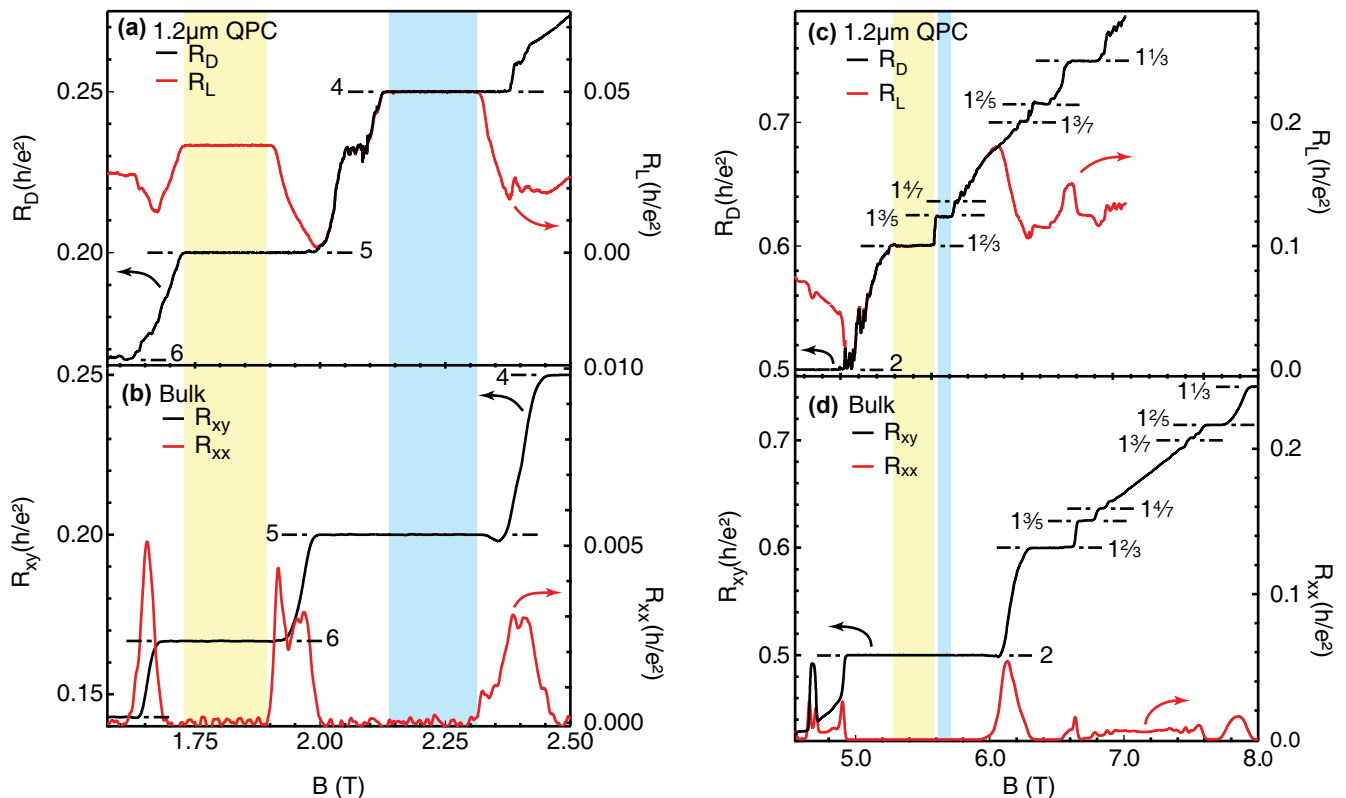

FIG. 3: Typical magnetoresistance curves measured concurrently in the QPC and the bulk at low magnetic field (a and b) and high magnetic field (c and d). Quantized resistance values are indicated in units of h/e^2 . The colored stripes indicate field ranges where one quantum Hall state exists in the QPC while a different quantum Hall state exists in the bulk. All data is for $T \sim 8$ mK.

voltage. Measurements are performed in a dilution refrigerator with base temperature 6 mK using standard four-wire lock-in techniques, with an ac current-bias excitation (I_{ac}) ranging from 0.2 nA to 0.86 nA, and a dc current-bias ranging from 0 to 20 nA. The differential resistances (dV/dI_{ac}) are measured in four places, as shown in Fig. 1. All quoted temperatures are measured using a RuO₂ resistor mounted on the mixing chamber. The bulk mobility of the device measured at base temperature is $2000 \text{ m}^2/\text{Vs}$ and the electron density is $2.6 \times 10^{15} \text{ m}^{-2}$.

Bulk R_{xx} and R_{xy} measurements for the filling fraction range $\nu_{\text{bulk}} = 3$ to 2, measured in the vicinity of the 1.2 μm QPC before the gates are energized, are shown in Fig. 2. R_{xx} and R_{xy} are also measured in a region of the Hall bar without gates, and found to be virtually indistinguishable, showing that the surface gates do not significantly affect the 2DEG. R_{xx} and R_{xy} in an ungated region show no changes caused by energizing gates.

As temperature is increased, R_{xy} near $\nu_{\text{bulk}} = 5/2$ evolves from a well-defined plateau at $R_{xy} = 0.4 \pm 0.0002 h/e^2$ to a line consistent with the classical Hall effect for a material with this density. There is a stationary point in the middle of the plateau where R_{xy} is very close to $0.4 h/e^2$, consistent with scaling seen in other quantum Hall transitions [47]. Activation energies Δ for the three

fractional states $\nu_{\text{bulk}} = 5/2$, $2^{1/3}$ and $2^{2/3}$ are extracted from the linear portion of the data in a plot of $\ln(R_{xx})$ vs $1/T$ (using the minimum R_{xx} for each FQHE state, and $R_{xx} \propto e^{-\Delta/2T}$), giving $\Delta_{2^{2/3}} \sim 60$ mK, $\Delta_{5/2} \sim 130$ mK and $\Delta_{2^{1/3}} \sim 110$ mK, consistent with previous measured values [1, 48, 49].

We now focus on measurements with one QPC formed, as shown in Fig. 1. Low-field R_D and R_L data from the 1.2 μm QPC along with concurrently measured R_{xy} and R_{xx} show regions where one IQHE state forms in the bulk with a lower IQHE state in the QPC (see Fig. 3a and Fig. 3b). Figure 3a also shows the appearance of a plateau-like feature in the QPC between $\nu_{\text{QPC}} = 5$ and $\nu_{\text{QPC}} = 4$ in both the 1.2 μm and 0.8 μm QPCs which remains unexplained. At higher magnetic fields (Fig. 3c and Fig. 3d), R_D and R_L show FQHE plateaus while the bulk is quantized at the IQHE value $\nu_{\text{bulk}} = 2$.

We now concentrate on the range $\nu_{\text{QPC}} = 3$ to $\nu_{\text{QPC}} = 2$ with $\nu_{\text{bulk}} = 3$ (Fig. 4). Plateau-like structure near $\nu_{\text{QPC}} = 5/2$ is evident in the 1.2 μm and 0.8 μm QPCs, but is not seen in the 0.5 μm QPC. Near $\nu_{\text{QPC}} = 2^{1/3}$ we also see plateau-like behavior in the 1.2 μm QPC, and somewhat less well developed plateaus in the 0.8 μm QPC (although ν_{bulk} is not on a plateau when $\nu_{\text{QPC}} \sim 2^{1/3}$), but again these features are suppressed in the 0.5 μm

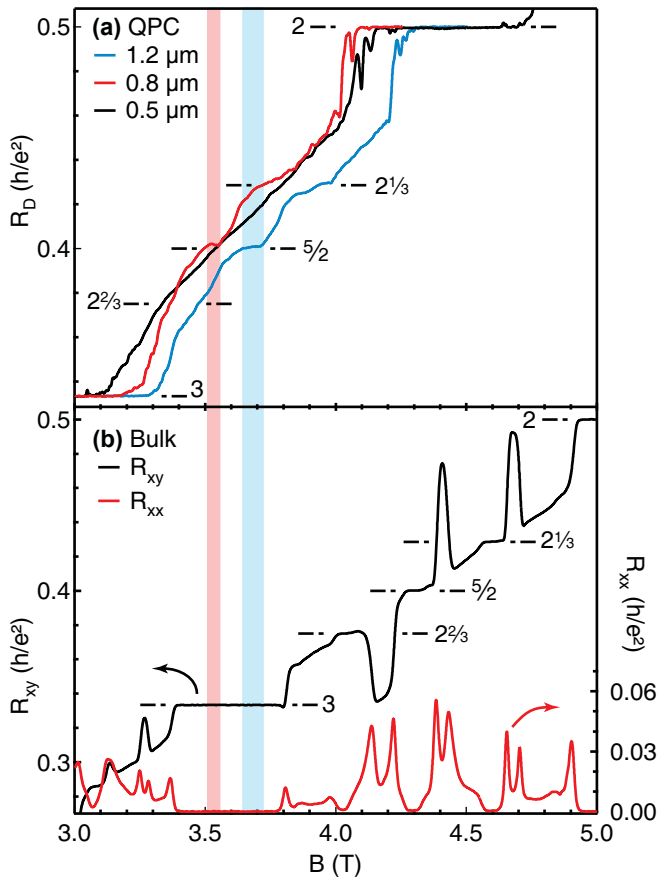

FIG. 4: Typical magnetoresistance from $\nu = 3$ to $\nu = 2$, measured concurrently in the QPC (a) and the bulk (b). In (a), the R_D curves are from three different QPCs, of lithographic size $0.5 \mu\text{m}$ (black), $0.8 \mu\text{m}$ (red) and $1.2 \mu\text{m}$ (blue). The colored stripes highlight regions in field where the resistance in the $1.2 \mu\text{m}$ and $0.8 \mu\text{m}$ QPCs forms a plateau-like feature near $\nu_{\text{QPC}} = 5/2$ with $\nu_{\text{bulk}} = 3$. The applied gate voltages V_g are -2.2 , -2.0 and -1.9V for the 1.2 , 0.8 and $0.5 \mu\text{m}$ QPCs and the ac lock-in excitation is 0.86nA . All data is for $T \sim 8 \text{mK}$.

QPC. We do not observe any plateaus near $\nu_{\text{QPC}} = 2/3$ in any of the QPCs. The reentrant integer quantum Hall effect features, which are clearly visible in the bulk, do not survive at all in the QPCs.

We interpret the plateau-like features in the two larger QPCs as indicating that the incompressible states at $\nu_{\text{QPC}} = 5/2$ and $\nu_{\text{QPC}} = 2/3$ are not destroyed by the confinement. The linear, plateau-less behavior in the $0.5 \mu\text{m}$ QPC is reminiscent of a classical Hall line, suggesting that no incompressible states survive in this QPC.

Temperature dependence for a representative V_g setting of the $1.2 \mu\text{m}$ QPC is shown in Fig. 5. Below 30mK , a distinct plateau-like feature is evident. This plateau disappears between 30 to 70mK , consistent with the disappearance of the plateaus in the bulk. However, unlike the bulk, where the $5/2$ plateau disappears symmetrically around a stationary point at $R_{xy} = 0.4 h/e^2$ as temperature increases, in the QPC there is an additional resis-

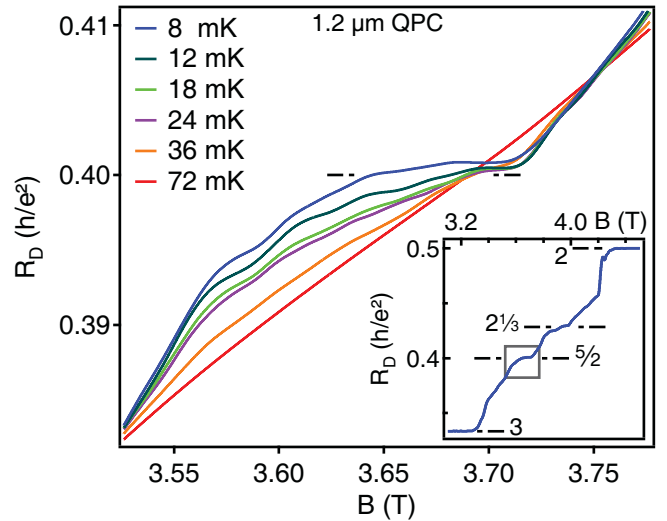

FIG. 5: Temperature dependence of the $5/2$ state in the $1.2 \mu\text{m}$ QPC. The inset shows an expanded range of the 8mK trace with the grey box indicating the range of the data in the main panel. All traces are measured with $V_g = -2.7 \text{V}$ and an ac lock-in excitation of 0.86nA . $\nu_{\text{bulk}} = 3$ for the entire B range of the main panel, but not the full range of the inset.

tance: R_D exceeds the quantized value of $0.4 h/e^2$ by $26 \Omega \pm 5 \Omega$. We also note that the extra resistance on the plateau decreases as the temperature increases, behavior consistently observed in both the $0.8 \mu\text{m}$ and $1.2 \mu\text{m}$ QPCs. We interpret this as indicating that the temperature dependence comes not only from the thermal excitation of quasiparticles, but also from the temperature dependence of their backscattering.

The dependence of the differential resistance on dc source-drain bias I_{dc} (Fig. 6) provides additional insight into this excess resistance. At base temperature, the resistances R_D vs I_{dc} near $\nu_{\text{QPC}} = 5/2$ and $\nu_{\text{QPC}} = 2/3$ in the $1.2 \mu\text{m}$ (Fig. 6c) and $0.8 \mu\text{m}$ (not shown) QPCs show pronounced peaks at $I_{\text{dc}} = 0$, a dip at intermediate values, and saturation to a constant value at high currents. In these QPCs, the I_{dc} behavior near $\nu_{\text{QPC}} = 2/3$ (not shown) is inverted, with a pronounced dip at $I_{\text{dc}} = 0$ a peak at intermediate values, and high-current saturation. In the $0.5 \mu\text{m}$ QPC the I_{dc} traces are flat for all filling fractions between $\nu_{\text{QPC}} = 3$ and $\nu_{\text{QPC}} = 2$. All the traces in Fig. 6 are measured with an ac-lock-in excitation $I_{\text{ac}} = 0.2 \text{nA}$, (while the data in all other figures have been measured with $I_{\text{ac}} = 0.86 \text{nA}$).

Fig. 6 provides a key point of comparison to previous experimental and theoretical work on the FQHE. In a recent experiment [28], a QPC is used to measure tunneling differential resistance characteristics (I_{dc} curves) for $\nu_{\text{QPC}} < 1$ while ν_{bulk} is fixed on an IQHE plateau. Our I_{dc} data for $2 < \nu_{\text{QPC}} < 3$ and $\nu_{\text{bulk}} = 3$, with a distinct peak at zero bias and dips at intermediate biases, resembles the I_{dc} curves in that work. In Ref. 28 it is

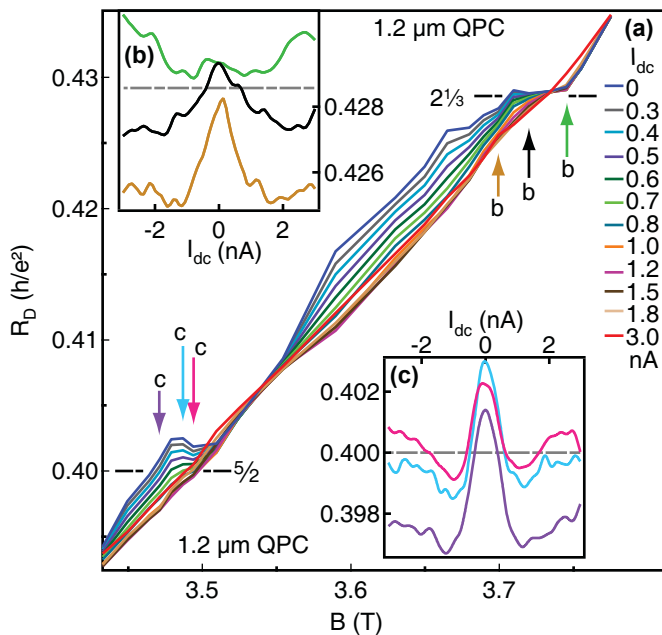

FIG. 6: Dependence upon dc current bias of the $5/2$ and $2^{1/3}$ states in the $1.2 \mu\text{m}$ QPC. The main panel (a) shows the R_D data as a function of magnetic field; each trace represents a different I_{dc} from 0 nA to 3 nA. R_D as a function of I_{dc} for selected magnetic fields (indicated by the color-coded arrows) are shown in (b) and (c). The dotted grey lines in the insets indicate resistance values of $3/7h/e^2$ (b) and $2/5h/e^2$ (c). All traces are measured at $T \sim 8 \text{ mK}$ with $V_g = -2.4 \text{ V}$ and an ac lock-in excitation of 0.2 nA. $\nu_{\text{bulk}} = 3$ for all fields shown in this figure.

convincingly argued that the I_{dc} curves are a signature of quasiparticle tunneling between the FQHE edge states, based on quantitative comparison to applicable theory. That theory states that the characteristic for tunneling between FQHE edge states [27, 37, 50] is expected to have a peak at zero bias and a minimum at intermediate biases, whereas tunneling between IQHE edge channels is expected to yield a flat (ohmic) curve. The data we present for $\nu_{\text{QPC}} = 5/2$, both the temperature dependence and the I_{dc} curves, are consistent with the formation of a FQHE state with tunneling-related backscattering.

We interpret that a mechanism for the deviation of R_D from $0.4h/e^2$ near $5/2$ and $2^{1/3}$, as well as the peak-and-dip behavior of the I_{dc} data, could be tunneling between edge channels on opposite sides of Hall bar in the vicinity of the QPC. We do not believe the data can be explained by transport via thermally excited particles through the (small) bulk region of the QPC, since this process would be expected to have the opposite temperature dependence.

We gratefully acknowledge helpful discussions with M. Fisher, B. Halperin, A. Johnson, E. Kim, B. Rosenow, A. Stern, X.-G. Wen and A. Yacoby. Research supported in part by Microsoft Corporation Project Q, and HCRP

at Harvard University, and ARO (W911NF-05-1-0062), the NSEC program of the NSF (PHY-0117795) and NSF (DMR-0353209) at MIT.

-
- [1] Willett R. *et al.*, *Phys. Rev. Lett.* **59** 1776 (1987).
 - [2] Eisenstein J.P. *et al.*, *Phys. Rev. Lett.* **61** 997 (1988).
 - [3] Eisenstein J.P. *et al.*, *Surf. Sci.* **229** 31 (1990).
 - [4] Pan W. *et al.*, *Phys. Rev. Lett.* **83** 3530 (1999).
 - [5] Pan W. *et al.*, *Phys. Rev. Lett.* **83** 820 (1999).
 - [6] Lilly M.P. *et al.*, *Phys. Rev. Lett.* **83** 824 (1999).
 - [7] Haldane F.D.M. and Rezayi E.H., *Phys. Rev. Lett.* **60** 956 (1988).
 - [8] Morf R.H., *Phys. Rev. Lett.* **80** 1505 (1998).
 - [9] Rezayi E.H. and Haldane F.D.M., *Phys. Rev. Lett.* **84** 4685 (2000).
 - [10] Moore G. and Read N., *Nucl. Phys. B* **360** 362 (1991).
 - [11] Greiter M., Wen X.G. and Wilczek F., *Phys. Rev. Lett.* **66** 3205 (1991).
 - [12] Read N. and Green D., *Phys. Rev. B* **61** 10267 (2000).
 - [13] Scarola V.W., Park K. and Jain J.K., *Nature* **406** 863 (2000).
 - [14] Nayak C. and Wilczek F., *Nuclear Physics B* **479** 529 (1996).
 - [15] Tserkovnyak Y. and Simon S.H., *Phys. Rev. Lett.* **90** 016802 (2003).
 - [16] Stern A., von Oppen F. and Mariani E., *Phys. Rev. B* **70** 205338 (2004).
 - [17] Stern A. and Halperin B.I., *Phys. Rev. Lett.* **96** 016802 (2006).
 - [18] Bonderson P., Kitaev A. and Shtengel K., *Phys. Rev. Lett.* **96** 016803 (2006).
 - [19] Hou C.Y. and Chamon C., *Phys. Rev. Lett.* **97** 146802 (2006).
 - [20] Chung S.B. and Stone M., *Phys. Rev. B* **73** 245311 (2006).
 - [21] Feldman D.E. and Kitaev A., *Phys. Rev. Lett.* **97** 186803 (2006).
 - [22] Kitaev A., *Ann. Phys. (N.Y.)* **332** (2006).
 - [23] Bonesteel N.E. *et al.*, *Phys. Rev. Lett.* **95** 140503 (2005).
 - [24] Das Sarma S., Freedman M. and Nayak C., *Phys. Rev. Lett.* **94** 166802 (2005).
 - [25] Harju A., Saarikoski H. and Räsänen E., *Phys. Rev. Lett.* **96** 126805 (2006).
 - [26] Töke C. and Jain J.K., *Phys. Rev. Lett.* **96** 246805 (2006).
 - [27] Fendley P., Ludwig A.W.W. and Saleur H., *Phys. Rev. B* **52** 8934 (1995).
 - [28] Roddaro S. *et al.*, *Phys. Rev. Lett.* **95** 156804 (2005).
 - [29] Fendley P., Fisher M.P.A. and Nayak C., *Phys. Rev. Lett.* **97** 036801 (2006).
 - [30] D'Agosta R., Vignale G. and Raimondi R., *Phys. Rev. Lett.* **94** 086801 (2005).
 - [31] Büttiker M., *Phys. Rev. Lett.* **57** 1761 (1986).
 - [32] Beenakker C.W.J. and van Houten H., *Solid State Physics* **44** 1 (1991), see discussions in Secs. IV.B and IV.C. Our R_D corresponds to R_D^+ in this reference.
 - [33] Beenakker C.W.J., *Phys. Rev. Lett.* **64** 216 (1990).
 - [34] MacDonald A.H., *Phys. Rev. Lett.* **64** 220 (1990).
 - [35] Chang A.M. and Cunningham J.E., *Solid State Comm.* **72** 651 (1989).
 - [36] Kouwenhoven L.P. *et al.*, *Phys. Rev. Lett.* **64** 685 (1990).

- [37] Wen X.G., *Phys. Rev. Lett.* **64** 2206 (1990).
- [38] Wang J.K. and Goldman V.J., *Phys. Rev. Lett.* **67** 749 (1991).
- [39] Würtz A. *et al.*, *Physica E* **22** 177 (2004).
- [40] van Wees B.J. *et al.*, *Phys. Rev. B* **38** 3625 (1988).
- [41] Alphenaar B.W. *et al.*, *Phys. Rev. Lett.* **64** 677 (1990).
- [42] Alphenaar B.W. *et al.*, *Phys. Rev. B* **45** 3890 (1992).
- [43] Lal S., *condmat/0611218* (2006).
- [44] Saminadayar L. *et al.*, *Phys. Rev. Lett.* **79** 2526 (1997).
- [45] de Picciotto R. *et al.*, *Nature* **389** 162 (1997).
- [46] Camino F.E., Zhou W. and Goldman V.J., *Phys. Rev. Lett.* **95** 246802 (2005).
- [47] Das Sarma S., in S. Das Sarma and A. Pinczuk, eds., *Perspectives in Quantum Hall Effects*, Wiley, New York (1997).
- [48] Eisenstein J.P. *et al.*, *Phys. Rev. Lett.* **88** 076801 (2002).
- [49] Xia J.S. *et al.*, *Phys. Rev. Lett.* **93** 176809 (2004).
- [50] Moon K. *et al.*, *Phys. Rev. Lett.* **71** 4381 (1993).