

Sensitivity of a micromechanical displacement detector based on the radio-frequency single-electron transistor

Miles P. Blencowe and Martin N. Wybourne

Department of Physics and Astronomy, Dartmouth College, Hanover, New Hampshire 03755

(November 20, 2018)

Abstract

We investigate the tunneling shot noise limits on the sensitivity of a micromechanical displacement detector based on a metal junction, radio-frequency single-electron transistor (rf-SET). In contrast with the charge sensitivity of the rf-SET electrometer, the displacement sensitivity improves with increasing gate voltage bias and, with a suitably optimized rf-SET, displacement sensitivities of $10^{-6} \text{ \AA}/\sqrt{\text{Hz}}$ may be possible.

PACS numbers: 85.30.Wx, 07.10.Cm, 73.50.Td

Recent advances in microfabrication technology have lead to renewed interest in demonstrating quantum behavior in small mechanical systems. Proposals include quantum tunneling,¹ quantum superposition states,² and the generation of nonclassical, squeezed states.³ A common requirement is the need to resolve sub-Ångstrom displacements at radio frequencies. Considering, for example, a micron-sized cantilever with a realisable resonant frequency of 100 MHz and a quality factor $Q \sim 10^4$,^{1,4} a displacement sensitivity of about 10^{-4} Å is required to detect quantum squeezing.³ Two methods for detecting motion of (sub)micron-scale structures are the magnetomotive technique⁵ and the optical interferometric technique,⁶ where sensitivities before signal averaging of around 10^{-2} Å/ $\sqrt{\text{Hz}}$ at 1 MHz were reported.

In the present letter, we consider the possibility of a metal junction single-electron transistor (SET)-based displacement detector for resolving sub-Ångstrom motion of micron-scale and smaller mechanical resonators with fundamental frequencies up to a few hundred MHz. A radio-frequency single-electron transistor (rf-SET) was developed a few years ago⁷ to overcome the limited bandwidth available in conventional SETs, and a rf-SET was recently used to investigate charge noise in an AlGaAs/GaAs quantum dot.⁸ In the original device,⁷ a bandwidth of around 100 MHz was demonstrated, a considerable improvement over conventional SET bandwidths of typically only a few kHz. The charge sensitivity of the rf-SET was $1.2 \times 10^{-5} e/\sqrt{\text{Hz}}$ at 1.1 MHz, comparable to the best sensitivities of low frequency SETs.⁹ In a recent theoretical analysis,¹⁰ Korotkov and Paalanen established that an additional order of magnitude improvement in the charge sensitivity could be expected with a suitably optimized device.

With the ability to operate at signal frequencies in the radio frequency range, we can expect considerable improvements in $1/f$ noise which limits the sensitivity of conventional SETs. Taking as our starting point the noise analysis of Korotkov *et al.*,¹⁰ we show below that metal SET displacement sensors may achieve shot-noise limited sensitivities of 10^{-6} Å/ $\sqrt{\text{Hz}}$. For the above cantilever example, this corresponds to an absolute displacement sensitivity

of 10^{-4} Å at 100 MHz, adequate for detecting quantum-squeezed motion.

With such improvements in displacement sensitivity, significant advances could also be made in understanding how mechanical energy is dissipated in micromechanical resonators. This problem is motivated in part by the increasing use of (sub)micron-sized cantilevers as sensors in new forms of force microscopy, such as the magnetic resonance force microscope, where the need to detect extremely weak forces requires smaller mass cantilevers with longer mechanical damping times.¹¹ Recent experiments which measure Q have provided strong evidence for surface defect relaxation as the dominant mechanism limiting the quality factor.^{4,6,12} However, more information could be gained about the relaxation dynamics if the damping motion of a micromechanical resonator could be measured with sufficient time and displacement accuracy to resolve the mechanical, random telegraph signals due to *single* defects undergoing relaxation.

The schema of the rf-SET displacement detector is shown in Fig. 1. The basic principle of the device involves locating one of the gate capacitor plates of the SET on the cantilever so that, for fixed gate voltage bias, a mechanical displacement is converted into a polarization charge fluctuation. The stray capacitance C_s of the leads contacting the SET and an inductor L form a tank circuit with resonant frequency $\omega_T = (LC_s)^{-1/2}$, loaded by the SET. A monochromatic carrier wave is sent down the cable. At the resonant frequency the circuit impedance is small and the reflected power provides a measure of the SET's differential resistance R_d .¹⁰ When the gate capacitor is biased, mechanical motion of the cantilever is converted into differential resistance changes, hence modulating the reflected signal power.

Consider an incoming wave of the form $V_{\text{in}} \cos \omega t$ at the end of the cable. The reflected wave is $V_{\text{ref}}(t) = v(t) - V_{\text{in}} \cos \omega t$, where the voltage $v(t)$ at the end of the cable satisfies the differential equation

$$\ddot{v}LC_s + \dot{v}R_0C_s + v = 2(1 - \omega^2LC_s)V_{\text{in}} \cos \omega t - R_0I_{SD}(t), \quad (1)$$

with R_0 the impedance of the cable and $I_{SD}(t)$ the SET source-drain current. Setting $\omega = \omega_T$ and substituting the Fourier decomposition $v(t) = \sum_{n=1}^{\infty} (X_n \cos n\omega t + Y_n \sin n\omega t)$ into Eq.

(1), we obtain for the Fourier coefficients

$$X_1 = 2\sqrt{L/C_s}\langle I_{SD}(t) \sin \omega t \rangle, \quad (2)$$

$$Y_1 = -2\sqrt{L/C_s}\langle I_{SD}(t) \cos \omega t \rangle, \quad (3)$$

where $\langle \dots \rangle$ denotes the time average and we restrict the analysis to the first harmonic of the reflected wave. The current $I_{SD}(t)$ depends on the voltage $V_{SD}(t)$ across the SET, which in turn depends on $v(t)$:

$$V_{SD}(t) = LR_0^{-1}[2V_{in}\omega \sin \omega t + \dot{v}(t)] + v(t). \quad (4)$$

The Fourier coefficients X_1, Y_1 are found by solving iteratively Eqs. (2) and (3). However, in the regime $R_d\sqrt{C_s/L} \gg Q_T \gg 1$, where the tank circuit quality factor $Q_T = R_0^{-1}\sqrt{L/C_s}$, we can approximate Eq. (4) as $V_{SD}(t) = 2Q_TV_{in} \sin \omega t$, thus the coefficients X_1, Y_1 are approximately solved for once the $I_{SD}(t)$ dependence on $V_{SD}(t)$ is known. We will also assume that the carrier frequency satisfies $\omega \ll \sqrt{\langle I_{SD}^2 \rangle}/e$. Under these conditions the current $I_{SD}(t)$ maintains a fixed phase relationship with respect to $V_{SD}(t)$ and, from the approximate form of $V_{SD}(t)$ and Eq. (3), we see that the time-averaging gives $Y_1 = 0$.

At the mechanical signal frequency f_s , where $2\pi f_s \lesssim \omega_T/Q_T$ (for example, with $\omega_T = 2\pi \times 1$ GHz and $Q_T = 10$, we have $f_s \lesssim 100$ MHz), the minimum detectable displacement δx in terms of the spectral density $S_X(f_s)$ of fluctuations in $X_1(t)$ is

$$\delta x = \sqrt{S_X(f_s)\Delta f/|dX_1/dx|}, \quad (5)$$

where Δf is the signal bandwidth and x denotes the displacement from equilibrium separation of the gate capacitor plates. The fundamental limit on δx is given by the intrinsic shot noise due to the SET tunneling current. Using the shot noise formula $S_I = 2eI$, which is approximately valid close to the tunneling threshold, and using Eq. (2) to relate S_X to the current spectral density S_I , Eq. (5) becomes

$$\delta x = \sqrt{2e\langle |I_{SD}(t)| \sin^2 \omega t \rangle \Delta f / |\langle dI_{SD}(t)/dx \sin \omega t \rangle|}. \quad (6)$$

All that remains is to determine the $I_{SD}(t)$ dependence on $V_{SD}(t)$ and substitute into Eq. (6). We use the “orthodox” theory¹³ and the method of analytic solution given in Ref. 14. Referring to Fig. 1, and as usual defining $C_\Sigma = C_1 + C_2 + C_g$, when the voltage amplitude across the SET $A = 2Q_T V_{in}$ is small compared to the voltage e/C_Σ , and also the thermal energy $k_B T \ll eA$, then the current in the tunneling region between stable regions of n and $n + 1$ excess electrons on the SET island can be well-approximated as

$$\begin{aligned} I_{SD} &= e[b_1(n) - t_1(n)]\rho(n) + e[b_1(n+1) - t_1(n+1)]\rho(n+1) \\ &= e[b_2(n) - t_2(n)]\rho(n) + e[b_2(n+1) - t_2(n+1)]\rho(n+1). \end{aligned} \quad (7)$$

Here the probabilities $\rho(n)$, $\rho(n+1)$ are given approximately as:

$$\begin{aligned} \rho(n) &= [t_1(n+1) + b_2(n+1)]/[b_1(n) + t_2(n) + t_1(n+1) + b_2(n+1)], \\ \rho(n+1) &= [b_1(n) + t_2(n)]/[b_1(n) + t_2(n) + t_1(n+1) + b_2(n+1)]. \end{aligned} \quad (8)$$

In this approximation the tunnel current peaks are well-separated in gate voltage V_g . The tunneling rates b_i (t_i) from the bottom (top) across the i th junction of the SET take the usual form.¹⁵

In Fig. 2 we show the dependence of the minimum detectable mechanical displacement δx on the gate voltage V_g , ranging over the first few current peaks. These results assume junction capacitance and resistance values $C_1 = C_2 = 0.25$ fF and $R_1 = R_2 = 50$ k Ω , and a static gate capacitance $C_g = 0.1$ fF. We have also explored the dependence of δx (optimized over V_g for given n) on the SET voltage amplitude A and also on an applied dc-voltage component. As was found for the charge sensitivity analysis,¹⁰ further improvements in the optimized δx are small.

Table I shows a sampling of δx values optimized with respect to V_g over a range corresponding to the rising (left) side of a given current peak. Importantly, the optimized minimum displacement resolution improves with increasing current peak number n . This is in marked contrast to the optimized minimum detectable charge which is independent of peak number. This trend begs the question of how large a gate voltage can be applied to a

metal junction SET. Given that electrometry is the most often considered SET application, for which there is no gain in charge sensitivity with increasing V_g (one current peak is as good as any other), this question has apparently received little attention. For displacement detection on the other hand, the optimized sensitivity improves with increasing V_g . There are no obvious reasons why the periodic current oscillations for a metal SET should not survive all the way up to the breakdown voltage between the gate capacitor plates. As V_g increases, progressively more electrons tunnel onto the island, screening the increasing polarization charge so that the periodicity in the V_g dependences of source-island and island-drain junction voltages is maintained. Assuming the gate capacitor plates are separated by a vacuum, and taking a typical vacuum breakdown voltage of 10^8 V/m,¹⁶ this suggests a maximum V_g of around 10 V across a $0.1 \mu\text{m}$ gap, on the order of the upper limit considered in the above noise analysis (Table I).

An alternative scenario to the one just outlined is suggested by the fact that fluctuators in the vicinity of the SET island can result in a strong gate-voltage dependence for the $1/f$ source-drain current noise.^{17,18} This raises the possibility of an optimum gate bias beyond which a further improvement in displacement sensitivity as predicted by the above shot noise analysis is offset by an increase in $1/f$ noise. Induced stresses in the gated cantilever as a result of its flexing motion may also affect the $1/f$ noise levels.¹⁹

To conclude, we have obtained the fundamental, shot noise limiting sensitivity of an rf-SET based displacement detector. In contrast with the charge sensitivity of an rf-SET electrometer, the optimized displacement sensitivity improves with increasing gate voltage. Sensitivities of $10^{-6} \text{ \AA}/\sqrt{\text{Hz}}$ may be possible, depending on one or other of the $1/f$ noise gate voltage dependence or the gate capacitance breakdown characteristics.

ACKNOWLEDGMENTS

We thank Chris Berven for helpful conversations.

REFERENCES

- ¹ A.N. Cleland and M.L. Roukes, in Proceedings ICPS-24, ed. D. Gershoni (World Scientific, Singapore, 1999).
- ² S. Bose, K. Jacobs, and P.L. Knight, Phys. Rev. A **59**, 3204 (1999).
- ³ M.P. Blencowe and M.N. Wybourne, Physica B **280**, 555 (2000).
- ⁴ A.N. Cleland and M.L. Roukes, Appl. Phys. Lett. **69**, 2653 (1996).
- ⁵ P. Mohanty, D.A. Harrington, and M.L. Roukes, Physica B **284**, 2143 (2000).
- ⁶ D.W. Carr, S. Evoy, L. Sekaric, H.G. Craighead, and J.M. Parpia, Appl. Phys. Lett. **75**, 920 (1999).
- ⁷ R.J. Schoelkopf, P. Wahlgren, A.A. Kozhevnikov, P. Delsing, and D.E. Prober, Science **280**, 1238 (1998).
- ⁸ T. Fujisawa and Y. Hirayama, Appl. Phys. Lett. (to appear).
- ⁹ B. Starmark, T. Henning, T. Claeson, P. Delsing, and A.N. Korotkov, J. Appl. Phys. **86**, 2132 (1999).
- ¹⁰ A.N. Korotkov and M.A. Paalanen, Appl. Phys. Lett. **74**, 4052 (1999).
- ¹¹ J.A. Sidles, J.L. Garbini, K.J. Bruland, D. Rugar, O. Züger, S. Hoen, and C.S. Yannoni, Rev. Mod. Phys. **67**, 249 (1995).
- ¹² K.Y. Yasumura, T.D. Stowe, E.M. Chow, T. Pfafman, T.W. Kenny, B.C. Stipe, and D. Rugar, IEEE Journal of Microelectromechanical Systems **9**, 117 (2000).
- ¹³ D.V. Averin and K.K. Likharev, in *Mesoscopic Phenomena in Solids*, eds. B.L. Altshuler, P.A. Lee, and R.A. Webb (Elsevier, Amsterdam, 1991).
- ¹⁴ M. Amman, R. Wilkens, E. Ben-Jacob, P.D. Maker, and R.C. Jaklevic, Phys. Rev. B **43**, 1146 (1991).

¹⁵ The tunneling rates are

$$b_i(n) = [\Delta E_i^-(n)/e^2 R_i] / [1 - e^{-\Delta E_i^-(n)/k_B T}],$$

$$t_i(n) = [\Delta E_i^+(n)/e^2 R_i] / [1 - e^{-\Delta E_i^+(n)/k_B T}],$$

where

$$\Delta E_1^\pm(n) = [-e/2 \pm (en - C_2 V_{SD} - C_g V_g)] e/C_\Sigma,$$

$$\Delta E_2^\pm(n) = [-e/2 \mp (en + (C_1 + C_g)V_{SD} - C_g V_g)] e/C_\Sigma.$$

Unlike the analysis of Korotkov *et al.*, the gate capacitance C_g must be included explicitly and not distributed between C_1 and C_2 , since the mechanical displacement dependence enters only through C_g .

¹⁶ X. Ma and T.S. Sudarshan, J. Vac. Sci. Technol. B **16**, 1174 (1998).

¹⁷ N.M. Zimmerman, J.L. Cobb, and A.F. Clark, Phys. Rev. B **56**, 7675 (1997).

¹⁸ J.C. Smith, M.N. Wybourne, C. Berven, R. Ramasubramaniam, and S.M. Goodnick, Europhys. Lett. **39**, 73 (1997).

¹⁹ J.M. Martinis, M. Nahum, and H.D. Jensen, Phys. Rev. Lett. **72**, 904 (1994).

TABLES

TABLE I. Minimum detectable displacement δx optimized with respect to V_g about a sampling of current peaks for increasing n . Note the linear dependence of the optimized δx on V_g for $n \gg 1$.

n	V_g (Volts)	$\delta x(\text{\AA})/\sqrt{\text{Hz}}$
1	2.5×10^{-3}	2.2×10^{-3}
10	1.9×10^{-2}	2.9×10^{-4}
10^2	0.18	3.0×10^{-5}
10^3	1.8	3.0×10^{-6}
10^4	18.1	3.0×10^{-7}

FIGURES

FIG. 1. Schema of the rf-SET displacement detector.

FIG. 2. Minimum detectable displacement as a function of gate voltage (upper, ‘doublet’ curves) corresponding to the first three I_{SD} current amplitude peaks. The current amplitude versus gate voltage is also shown (lower curve - arbitrary scale) for reference. The noise analysis assumes a symmetric rf-SET at $T = 30$ mK ($= 0.01 e^2/C_\Sigma$) with junction capacitances $C_1 = C_2 = 0.25$ fF, junction resistances $R_1 = R_2 = 50$ k Ω , and static gate capacitance 0.1 fF (corresponding to $1 \mu\text{m}^2$ plate area and $0.1 \mu\text{m}$ plate gap). The source-drain rf bias voltage amplitude is $A = 10^{-4}$ V ($= 0.4 e/C_\Sigma$).

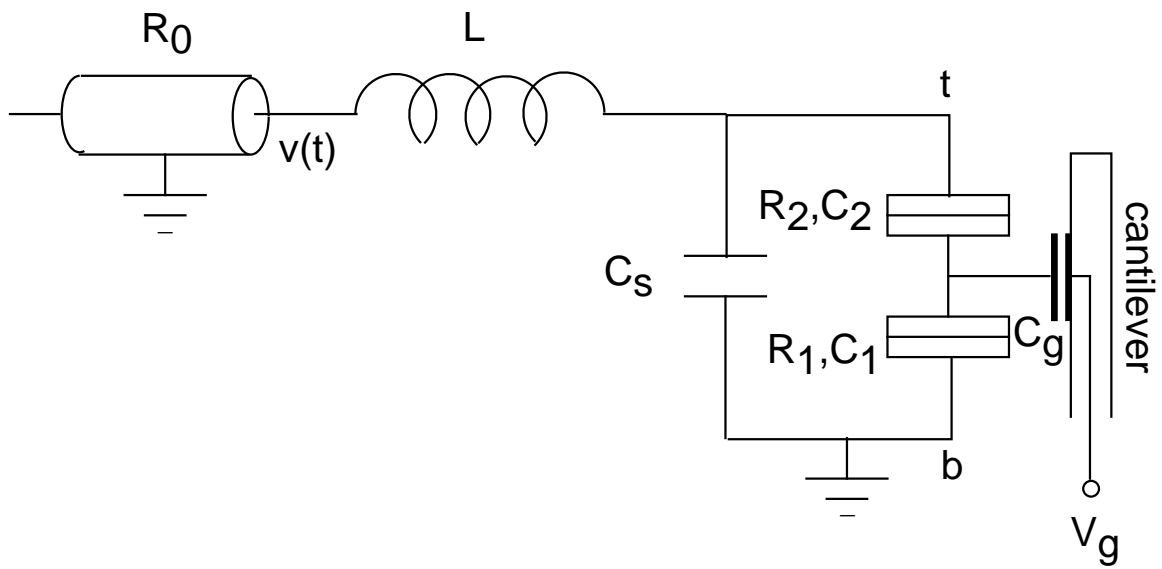

Fig. 1 Blencowe

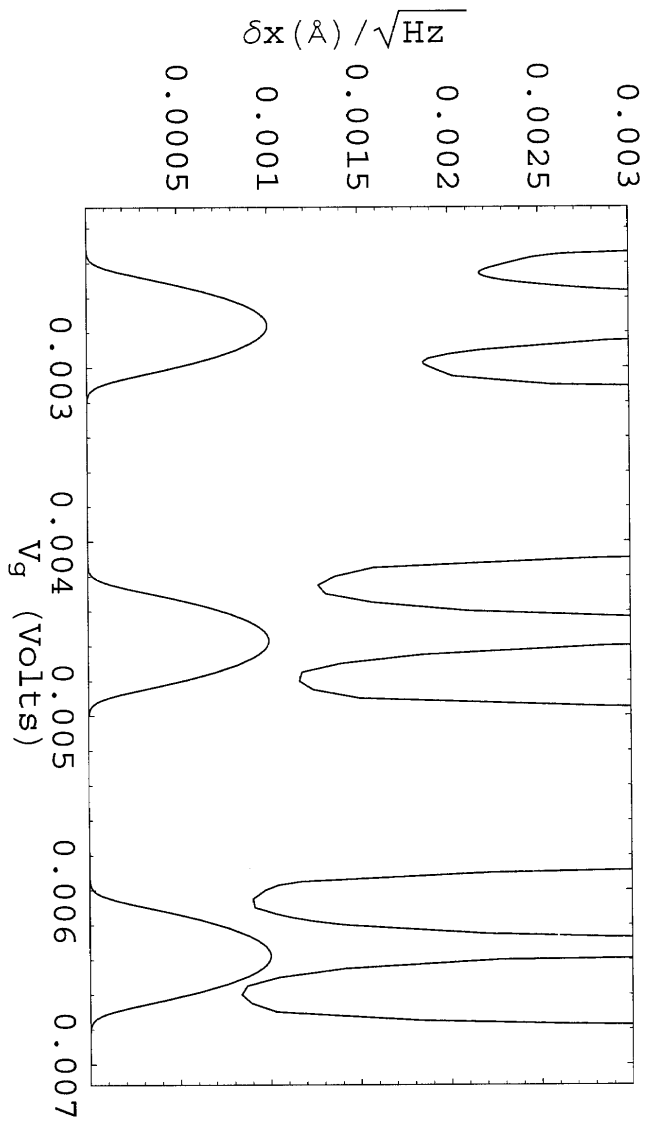

Fig. 2 Blencowe