

SmB₆: Topological insulator or semiconductor with valence-fluctuation induced hopping transport?

I. Batko* and M. Batkova†

*Institute of Experimental Physics, Slovak Academy of Sciences,
Watsonova 47, 040 01 Košice, Slovakia*

(Dated: November 5, 2018)

Abstract

We advert to the fact that presence of valence fluctuations (VFs) in semiconductors with in-gap impurity bands unconditionally leads to dynamical changes (fluctuations) of energies of localized impurity states. We provide arguments that in the impurity subnetwork consisting of centers having energy levels fluctuating around the Fermi energy there exist favorable conditions for hops from occupied states to empty states of less energy. Consequently, we propose original *valence-fluctuation induced* hopping mechanism as a new possibility to explain unusual metallic-like conduction of SmB₆ and other Kondo insulators experimentally observed at lowest temperatures. Interestingly, the proposed mechanism infers enhanced metallic-like surface conductivity of SmB₆, what resembles a characteristic property of topological insulator, and is in agreement with experimental observations attempting to prove the existence of topologically protected surface state in SmB₆.

*Electronic address: batko@saske.sk

†Electronic address: batkova@saske.sk

SmB₆ belongs to the class of materials known as heavy-fermion semiconductors, or alternatively as Kondo insulators [1]. These materials are characterized by electronic properties, which at high temperatures are associated with a set of independent localized (*f*) magnetic moments interacting with a sea of conduction electrons, while at low temperatures their electronic properties resemble those of narrow gap semiconductors [1–3]. Specifically for SmB₆, a small electronic gap ($\Delta = 2 - 30$ K) was detected by many experimental techniques, e.g. optical conductivity [4], infrared absorption [5, 6], inelastic neutron scattering [7], electron tunneling [8–10], and electrical transport measurements [10–16].

A fundamental phenomenon that governs physical properties of SmB₆ is intermediate valence (or homogeneously mixed valence) of Sm ions that fluctuate between Sm²⁺ ($4f^6$) and Sm³⁺ ($4f^55d^1$) configurations [2]. The Sm²⁺ : Sm³⁺ ratio at room temperature is about 4 : 6 and varies with temperature weakly, as established by measurements of lattice constant [18], x-ray absorption [18], and Mössbauer studies [19]. Studies of spin and charge fluctuations due to $\text{Sm}^{2+} \rightleftharpoons \text{Sm}^{3+} + d$ fluctuations indicate fluctuation rates in the range of phonon frequencies; the spin fluctuation time obtained via ¹⁰B and ¹¹B NMR between 2 and 300 K yields a spin fluctuation rate $\tau_{sf}^{-1} \sim 10^{13} \text{ s}^{-1}$ [20], while phonon spectroscopy studies indicate charge fluctuations between 200 cm⁻¹ and 650 cm⁻¹ [21, 22], what corresponds to the characteristic charge fluctuation rate, τ_{cf}^{-1} , between $6 \times 10^{12} \text{ s}^{-1}$ and $2 \times 10^{13} \text{ s}^{-1}$.

Although SmB₆ and other Kondo insulators have been intensively studied for more than four decades, many fundamental aspects of the microscopic description of the mixed valence ground state and the nature of the VFs are still under discussion [3]. One of the principal questions is whether Kondo insulating materials actually are true insulators at low temperatures or whether small conduction-electron carrier concentration is present [3, 23]. Answering this question is especially complicated in the case of SmB₆ due to a fundamental problem to interpret consistently the electrical resistivity/conductivity behavior at lowest temperatures.

Electrical resistivity measurements of SmB₆ show a large resistivity increase at decreasing temperature below 50 K, and saturation at very high residual value ρ_0 at lowest temperatures [12–16]. The corresponding electrical conductivity $\sigma(T) = 1/\rho(T)$ in the "saturation region" is metallic-like and reveals a temperature non-activated (metallic) channel in $\sigma(T)$, which becomes dominating below about 3 K [13–17]. This residual conductivity can be attributed to in-gap states, which were confirmed by other probes [5, 6, 24, 25]. However, detailed si-

multaneous studies of the resistivity and Hall resistivity performed on highest quality SmB_6 samples indicate that very high value of ρ_0 would require a superunitary scattering [12, 14] with unphysically high concentration of scattering centers (at least 80 per unit cell [14]). Taking into account the Mott-Ioffe-Regel viewpoint, which claims that the conventional Boltzmann transport theory becomes meaningless when the characteristic mean free path of the itinerant conduction electrons becomes comparable to, or less than the interatomic spacing [26–28], the very high value of the residual resistivity in SmB_6 cannot be attributed to metallic conductivity mediated by itinerant electrons. Thus, some kind of hopping transport is required to describe the conductivity of SmB_6 at lowest temperatures. However, hopping-type conduction within the framework of present theoretical models requires a temperature activated conductivity and an insulating ground state, what is in qualitative disagreement with the above mentioned experimental indications [13–17]. Hence, the origin of the residual resistivity/conductivity in SmB_6 can not be consistently explained considering any known mechanism of electrical conductivity in metals or semiconductors if a homogeneous bulk conduction is considered to be responsible for the observed electrical conductivity. Possible solution of this mystery represents recent proposition that SmB_6 is a topological Kondo insulator [29–31], so that topologically protected metallic surface states can be responsible for the anomalously high residual resistivity. Although several studies indeed indicate metallic surface transport in SmB_6 [32–34], the question about nature of the surface states in SmB_6 remains open. Moreover, new points of view on the origin of the surface enhanced conductivity in SmB_6 were recently presented, e.g. polarity driven surface metalicity in SmB_6 [35] or coexistence of non-trivial 2D surface state and trivial surface layer [36].

The purpose of this paper is to show that there exists also other possibility to explain mysterious residual resistivity of SmB_6 within the concept of hopping transport, if effect of VFs of samarium ions on the energy of in-gap impurity states is taken into consideration. Our explanation is based on the fact that $\text{Sm}^{2+} \rightleftharpoons \text{Sm}^{3+} + d$ fluctuations of valence are *intrinsically* associated with fluctuations of charge, magnetic moments and ionic radii of samarium ions. Because all these parameters influence the interaction energy of an impurity center with the surrounding lattice (thus influencing the energy of corresponding localized impurity state) it has to be concluded that fluctuations of the mentioned parameters will *unconditionally* cause fluctuations of energies of localized impurity states in the impurity band of SmB_6 . As we show in this paper, just fluctuations of energies of impurity states ”driven” by VFs may

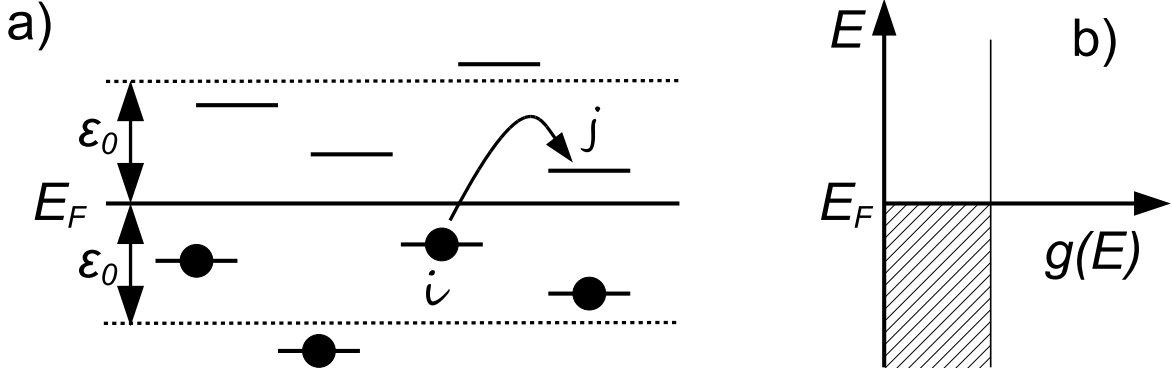

FIG. 1: Schematic depiction of states from the impurity band with energies lying in the vicinity of the Fermi energy in case of a classic semiconductor (a), and corresponding DOS diagram (b).

give rise to a new type of hopping mechanism, which is energetically more favorable at lowest temperatures than the well-known variable-range hopping (VRH). Hopping probability in this new hopping mechanism is governed by dynamics of valence fluctuations and by a characteristic distance between hopping centers, what in case of increased concentration of hopping centers in the surface layer yields correspondingly increased hop probability in the surface layer. The proposed hopping mechanism can be responsible for metallic-like conduction of SmB_6 at lowest temperatures, as follows from the analysis and the discussion presented below.

Let us start with a model case of a classic semiconductor having a simple cubic crystal lattice with the lattice parameter a , containing metal ions, Me , positioned in the centers of the elementary cells. Let's also suppose that metal ions are in two different valency states, say Me^{2+} and Me^{3+} , where Me^{2+} and Me^{3+} ions are randomly distributed over the metal ion positions, while their valences are “static”, i.e. they do not change in time. In addition, let us suppose that (i) the considered semiconductor contains localized donor impurity states that form IB in its forbidden gap, (ii) the Fermi energy, E_F , lies in the IB, and (iii) the IB in the vicinity of the Fermi energy is characterized by a constant density-of-states (DOS) function, $g(E)$. The supposed situation is similar to that well-known for doped (classic) semiconductors as schematically depicted in Fig. 1 (see e.g. [28, 38]). So, it is reasonable to suppose that electrical conduction in such system is temperature activated at low temperatures and can be adequately described by hopping process utilizing the concept of Miller-Abrahams network [39], where randomly distributed impurities form a resistance

network, having the nearest neighboring impurities at a typical distance $R \gg a$ [28, 37, 38]. However, as noted for the first time by Mott [37], the activation energy needed to hop should in principle drop to zero at lowest temperatures, from the following reasons. If the electron hops a much bigger distance (say pR with $p \gg 1$) it has a choice of p^3 as many sites and may expect to find some with an energy nearer to its own, say with energy difference W_D/p^3 [37], where W_D is activation energy defined by Miller and Abrahams [39] as the average energy needed to hop to nearest neighboring impurities at distance R . Hopping probability for hops to distance pR may be written as proportional to [37]

$$e^{(-2\alpha pR - W_D/p^3 kT)}, \quad (1)$$

where α^{-1} is a localization length. Expression (1) has a maximum when [37]

$$p^4 = 3W_D/2\alpha RkT. \quad (2)$$

As concluded by Mott, if (2) gives a value of p greater than unity, the hopping probability is no longer proportional to $e^{-W_D/kT}$ but obeys the proportionality

$$P_{Mott} \propto e^{-(T_0/T)^{1/4}}, \quad (3)$$

where $T_0 = \text{const.}(\alpha R)^3 W_D/k$ [37], and P_{Mott} is corresponding hopping probability. Thus, according to the original Mott's analysis and other more detailed works [28, 37, 38, 40], conductivity due to electron hops of our model system containing Me^{2+} and Me^{3+} ions can be written as proportional to $e^{-(T_0/T)^{1/4}}$ at lowest temperatures, while a typical activation energy of a hop, $\epsilon_0 \approx W_D/p^3$, decreases with temperature as $T^{3/4}$. It can be said that conduction arises from the phonon assisted hopping with a typical activation energy ϵ_0 in a so-called optimal band, where the optimal band is defined as a narrow energy interval of the width $2\epsilon_0$ centered at the Fermi level (see Fig. 1a) with concentration of impurities [38]

$$N(\epsilon_0) = 2\epsilon_0 g(E_F). \quad (4)$$

Because concentration of impurities in the optimal band decreases with temperature and approaches zero for $T \rightarrow 0$ [$N(\epsilon_0) \propto \epsilon_0 \propto T^{3/4}$], a typical hop distance ($\propto T^{-1/4}$) goes to infinity for $T \rightarrow 0$, resulting in insulating ground state.

Now, let us "turn on" a *hypothetical* rearrangement process (RP) in the considered semiconductor that causes repetitious changes in distribution of Me^{2+} and Me^{3+} ions on metal

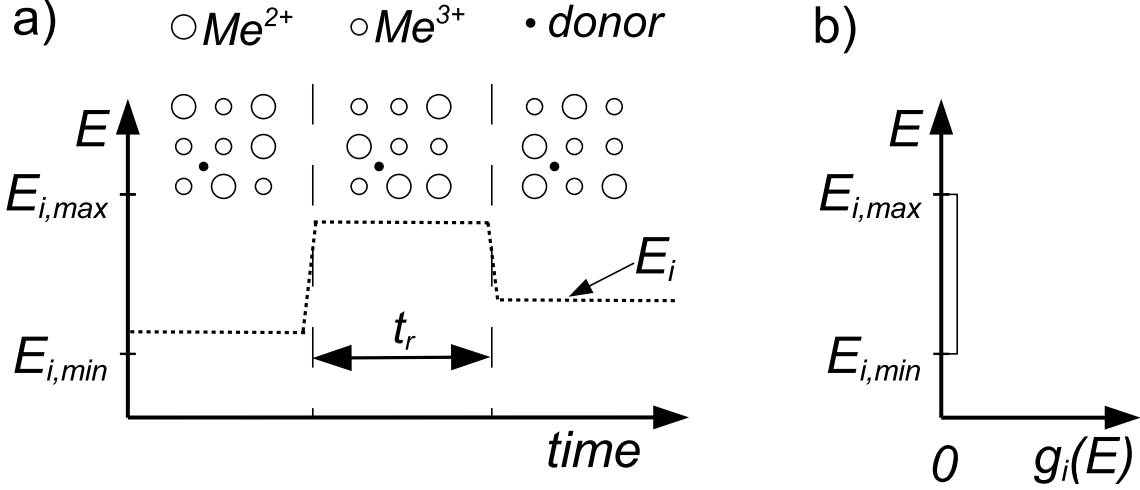

FIG. 2: Time evolution of donor energy E_i due to rearrangement process of metallic ions (a) and corresponding time-averaged partial DOS (b) of the donor state. Rearrangement process in this example is realized as clockwise rotation (90 degrees) of metallic ions around "central" Me^{3+} ion.

ion positions with a characteristic time constant, t_r . We consider only such rearrangements, where the number of Me^{2+} and Me^{3+} ions is not changed (i.e. RP is realized via position interchanges of some Me^{2+} and Me^{3+} ions) and the macroscopic physical properties of the system remain unchanged. (The situation is depicted in Fig. 2.) Due to different physical properties of Me^{2+} and Me^{3+} ions, changes in space distribution of Me^{2+}/Me^{3+} ions surrounding an impurity will correspondingly change interaction of the impurity with the surrounding lattice. For instance, "replacement" of Me^{2+} by Me^{3+} (with relatively smaller radius) will decrease local chemical pressure acting on the neighboring impurity center and increase the attractive Coulomb interaction between the (donor) impurity center and the metal ion. Therefore, RP-caused different redistributions of Me^{2+}/Me^{3+} ions surrounding an impurity center i will result in different energy of the corresponding localized impurity state, E_i , thus E_i will change with a characteristic time constant t_r of the RP, as schematically shown in Fig. 2a. Performing all possible rearrangements as defined above (i.e. all possible distributions of Me^{2+}/Me^{3+} ions that do not change macroscopic/bulk physical properties of the material), the energy E_i will change within the interval expressed by the inequality

$$E_{i,min} \leq E_i \leq E_{i,max}. \quad (5)$$

Here, $E_{i,min}$ and $E_{i,max}$ ($E_{i,min} < E_{i,max}$) are the minimum and maximum possible energy of the donor, respectively. So that, as follows from the arguments above, the energy of localized impurity/donor state changes with every rearrangement, and lies in energy interval of non-zero width

$$\Delta E_i = E_{i,max} - E_{i,min} > 0. \quad (6)$$

In other words, the localized impurity/donor state is not longer characterized by energy constant in time (like in semiconductor with absence of RP as depicted in Fig. 1a), but by energy interval (resembling a narrow band), e.g. like shown in Fig. 2b. Probability of finding the localized impurity/donor state i at the energy E is characterized by partial-DOS function $g_i(E)$, which is zero outside the interval defined by inequality (5), but might have rather “complex shape” within this interval. For purposes of this paper $g_i(E)$ is considered to be constant within the interval defined by inequality (5), as depicted in Fig. 2b.

RP-caused changes of energy of localized impurity states in time have principal impact on hopping process. According to our original supposition, E_F lies in the IB which is characterized by a constant DOS, and we consider only such redistributions of Me^{2+}/Me^{3+} ions that do not change physical characteristics of the system (i.e. DOS of the whole macroscopic system remains unchanged). Thus, there have to exist impurity centers i^* with corresponding energy if localized states E_{i^*} satisfying the condition $E_{i^*,min} < E_{i^*} < E_{i^*,max}$, such that

$$E_{i^*,min} < E_F < E_{i^*,max}. \quad (7)$$

Assuming for simplicity that impurity states are characterized by an equal/typical width of the energy interval $\Delta E_i \approx E_0$, then energies of impurity centers E_{i^*} which due to RP can be less, as well as greater than E_F , satisfy the inequality

$$E_F - E_0 < E_{i^*} < E_F + E_0. \quad (8)$$

The concentration of such centers is

$$N^*(E_0) = E_0 g(E_F). \quad (9)$$

Correspondingly, a typical distance between two nearest centers is

$$R^* = [N^*(E_0)]^{-1/3} = [E_0 g(E_F)]^{-1/3}. \quad (10)$$

Impurity centers defined by (8) have a unique property; there exists a non-zero probability that some occupied donor levels will shift due to RP from the region below E_F to the region above E_F , and analogously, some empty donor levels from the region above E_F will shift under E_F . Such energy changes represent in fact non-equilibrium excitations (driven by RP) that have to be consequently brought into the equilibrium state, what happens via electron hops of “zero activation energy” from occupied states to empty states of less energy. This in fact, indicates a possibility of new hopping mechanism, which should be realized via temperature non-activated hops (tunneling) that have to dominate at lowest temperatures. Let us analyze the situation in more details.

The intrinsic transition rate γ_{ij} for an electron hopping from a site i with energy E_i to an empty site j with energy E_j in the simplest case, when kT is small compared to $|E_j - E_i|$, and $|E_j - E_i|$ is of the order of the Debye energy or smaller, is well approximated by the “quantum-limit” hopping formula [40]

$$\gamma_{ij} = \gamma_0 e^{-2\alpha R_{ij} - (E_j - E_i)/kT} \text{ for } E_j > E_i \quad (11)$$

$$\gamma_{ij} = \gamma_0 e^{-2\alpha R_{ij}} \text{ for } E_j < E_i, \quad (12)$$

where γ_0 is a constant as defined elsewhere [40] and R_{ij} is the distance between the centers i and j . Bidirectional hopping process between the centers i and j ($i \rightarrow j \rightarrow i \rightarrow j \dots$), in a classic semiconductor (without RP) unconditionally requires thermal activation, because bidirectional hopping always includes also hops to empty states of higher energy [see (11) and Fig. 1a]. For instance, if the first hop is one to a site of less energy, it does not require thermal activation [as follows from (12)]. However, the following hop in opposite direction has to be one to a state of higher energy (see Fig. 1a), so it requires temperature activation [as follows from (11)]. This implicates that bidirectional hopping process is conditioned by energy (phonon) absorption. [In fact, substitution of R_{ij} and $(E_j - E_i)$ in (11) by typical hop distance pR and activation energy W_D/p^3 , respectively, yields the same exponential term as (1), which in accordance with Mott’s original deviation [37] (as summarized in the beginning) leads to VRH-conductivity proportional to $e^{-(T_0/T)^{1/4}}$.]

The situation is qualitatively different in a semiconductor, where RP of metal ions Me^{2+}/Me^{3+} takes place, thus energies of impurity states change in time. Let’s consider two impurity states (i, j) that have non-zero overlap of their energy intervals (say $E_{j,min} < E_{i,min} < E_{j,max} < E_{i,max}$ like shown in Fig. 3), and RP causing repetitive changes

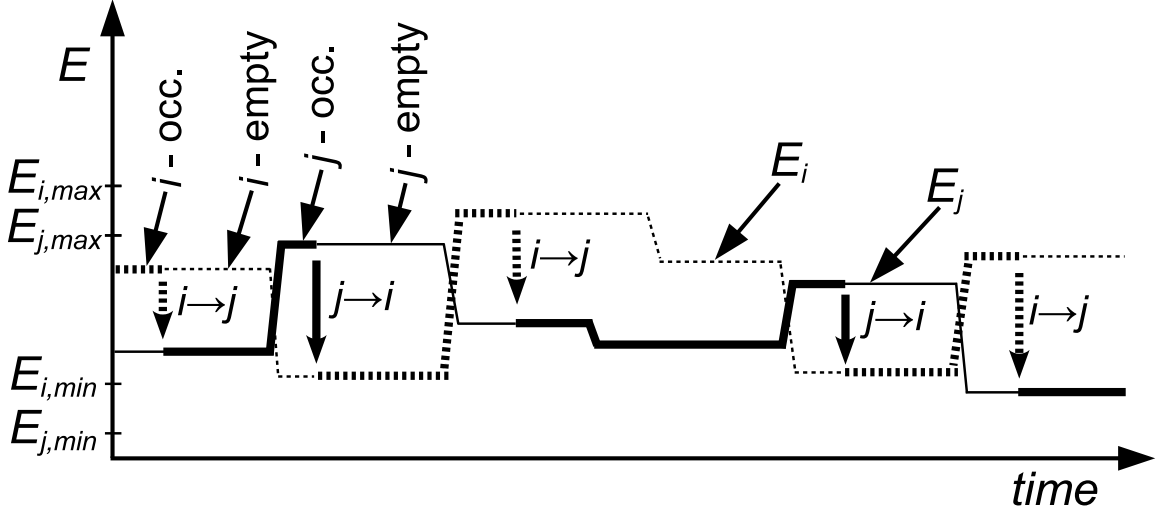

FIG. 3: Schematic depiction of bidirectional hopping between states i and j due to rearrangement processes. Time evolution of energy of i and j state is represented by dashed and solid line respectively, while occupation of the state is represented by the line thickness (thick - occupied, thin - empty). Hops from i and j states are indicated by vertical arrows with dashed and solid lines, respectively.

of mutual positions of energy levels E_i and E_j . If the first hop (say $i \rightarrow j$) is from an impurity site of (temporarily) higher energy to one of less energy (i.e. $E_i > E_j$) then it does not require thermal activation (see Fig. 3). However, there exist *two* possibilities for the hop in the opposite direction ($j \rightarrow i$): (i) the hop will require thermal activation if performed during the time period when $E_j < E_i$, or (ii) the hop will be performed without thermal activation *after* at least one rearrangement of metal ions Me^{2+}/Me^{3+} causing mutual change of relative positions of energy levels E_i and E_j , when E_j becomes (temporarily) greater than E_i , as schematically depicted in Fig. 3. Introducing a parameter ν_{ij} ($0 < \nu_{ij} < 1$) denoting the probability that an occupied state i occurs due to RP at (temporarily) higher energy level than an empty state j , then the intrinsic transition rate $\gamma_{ij}^{non-act}$ for thermally non-activated electron hop from site i to site j with (temporarily) less energy will be

$$\gamma_{ij}^{non-act} = \nu_{ij} \gamma_0 e^{-2\alpha R_{ij}}, \quad (13)$$

while the intrinsic transition rate γ_{ij}^{act} for thermally activated electron hop from site i to site j (with temporarily higher energy) will be

$$\gamma_{ij}^{act} = (1 - \nu_{ij}) \gamma_0 e^{-2\alpha R_{ij} - (E_j - E_i)/kT}. \quad (14)$$

If the ratio

$$\beta_{ij} = \frac{\gamma_{ij}^{non-act}}{\gamma_{ij}^{act}} = \frac{\nu_{ij}}{(1 - \nu_{ij})e^{-(E_j - E_i)/kT}} \quad (15)$$

is greater than unity, the predominating electron hops between impurity states i and j are not longer thermally activated, but thermally non-activated hops to states with less energy that are “induced” by RP. Because for every non-zero ν_{ij} there exists a temperature T_{ij} providing $\beta_{ij} \gg 1$ for $T < T_{ij}$, intrinsic transition rate γ_{ij} of the considered bidirectional hopping process at lowest temperatures can be in *both directions* approximated by

$$\gamma_{ij} \approx \nu_{ij} \gamma_0 e^{-2\alpha R_{ij}}. \quad (16)$$

However, this practically means that for $T \rightarrow 0$ there is no need for electron to hop to empty state of higher energy, because it is energetically more favorable to “wait” for a “proper” rearrangement of Me^{2+}/Me^{3+} ions causing that empty state of less energy occurs (just as it is schematically shown in Fig. 3).

Considering subnetwork of impurities satisfying the inequality (8) we define ν_{rp}^* as the time-averaged probability per unit volume that for a *temporarily* occupied state belonging to the subnetwork, an empty state from the subnetwork will appear at lower energy as a consequence of RP. Considering electron hops to sites within the distance pR^* , where $p \geq 1$ and R^* is given by Eq. (10), electron has choice of p^3 as many sites to find an empty state of less energy. Probability of such RP-induced hop, P_{rp}^* , can be expressed as

$$P_{rp}^* \propto p^3 \nu_{rp}^* e^{-2\alpha p R^*}, \quad (17)$$

and has maximum for $p = 3/2\alpha R^*$. If value $3/2\alpha R^* \geq 1$, maximum probability of RP-induced hop can be (omitting numerical factors) expressed as

$$P_{rp}^* \propto \nu_{rp}^* / (\alpha R^*)^3. \quad (18)$$

However, estimation of αR in classic doped semiconductors ($R^* \geq R \gg a$) [42] indicates values $3/2\alpha R^* < 1$. Therefore, predominated hops should be realized to distance $pR^* \approx R^*$ (i.e. nearest-neighbor hopping within the considered subnetwork). So, we take $p \equiv 1$ to maximize (17), which can be then expressed in the form

$$P_{rp}^* \propto \nu_{rp}^* e^{-2\alpha R^*}. \quad (19)$$

Taking into account that both parameters ν_{rp}^* and R^* have finite and non-zero values resulting from RP, and considering that RP is not temperature dependent, it can be concluded that electron hopping induced by RP is temperature non-activated.

The above sketched scenario reveals how RP of metal ions of different valencies in the semiconductor lattice can *qualitatively* change nature of hopping process. While the hop probability P_{Mott}^* given by proportionality (3) for a system without RP is temperature-activated, presence of RP causes that probability of hops P_{rp}^* that dominate at lowest temperatures is temperature non-activated. This unique property can be effectively used to explain metallic-like conductivity of SmB_6 at lowest temperatures.

Several experimental studies reveal that SmB_6 can be adequately treated as a system with IB in the forbidden gap, and with the Fermi energy lying in the IB. Because of nature of VFs, valence fluctuations between Sm^{2+} and Sm^{3+} will effect energies of localized impurity states similarly as RP in the model above, i.e., the VFs will cause time-dependent changes (fluctuations) of energy levels of impurity states. (See Fig. 2 and consider $\text{Sm}^{2+}/\text{Sm}^{3+}$ ions instead of Me^{2+}/Me^{3+} ones.) So that, impurity states in SmB_6 are expected to be characterized by energy fluctuating in intervals of non-zero width instead of energy levels with energy constant in time. According to the above proposed scenario, and assuming that Fermi energy lies in the impurity band of SmB_6 , then there will exist impurity subnetwork consisting of impurity centers satisfying condition (8). Hence, mutual position of energies corresponding states in comparison with E_F is dynamically changing (fluctuating), while characteristic rate of these changes is closely related to a characteristic rate VFs. This implicates favorable conditions for hops to empty states of less energy at high hopping rates, which can, in principle, approach rates of VFs. So, based on (19), which we consider as a relevant case to discuss bulk properties of SmB_6 [$R^* \geq R \gg a(\text{SmB}_6)$], we can write probability of hops induced by VFs in the considered subnetwork, P_{vf}^* , as

$$P_{vf}^* \propto \nu_{vf}^* e^{-2\alpha R^*}. \quad (20)$$

Here ν_{vf}^* is defined analogously as ν_{rp}^* , accepting the fact that VFs, in principle, represent a special case of RP. Because both parameters ν_{vf}^* and R^* are governed by *dynamical* processes having origin in VFs (e.g. charge or spin fluctuations), temperature dependence of the probability of VFs-induced hops can be introduced only via effect of temperature on these processes. However, if we take into account generally accepted fact that ground state

of SmB₆ is valence fluctuating state [1–3], then we have to conclude that parameters describing dynamics of VFs (e.g. charge fluctuation rate, τ_{cf}^{-1}) do not converge to zero for $T \rightarrow 0$. From this reason, ν_{vf}^* (which is affected by *all* processes governing fluctuations of impurity energy levels), can not be described by a temperature-activated law, because in such case τ_{cf}^{-1} would have to go to zero for $T \rightarrow 0$, thus the ground state could not be a valence fluctuating state. Hence, the observed temperature non-activated conduction of SmB₆ at lowest temperatures can be reasonably explained by a temperature non-activated nature of dynamics of VFs, which induces temperature non-activated hopping with probability described by (20). From this point of view, observation of almost constant resistivity in SmB₆ at lowest temperatures indicates that dynamics of VFs in SmB₆ is almost temperature independent for $T \rightarrow 0$. It can be also said that temperature dependent changes of dynamics of VFs, which consequently influence parameter ν_{vf}^* , should be directly reflected in temperature behavior of electric conduction, as follows from (20). Thus, the proposed scenario not only gives possible explanation for metallic-like resistivity behavior of SmB₆, but also gives new physical meaning and interpretation to electrical conductivity data of SmB₆ and other valence fluctuating semiconductors at temperatures approaching absolute zero temperature.

Here should be noted that because of the fact that electrical transport is realized via hopping process, corresponding electrical conductivity can be less than the minimum metallic conductivity σ_{min} defined by Mott-Ioffe-Regel criterion. So, the proposed scenario naturally explains why residual conductivity of SmB₆ can be less than σ_{min} without need to consider some combination of bulk semiconducting properties (obeying the criterion) and unusual metallic surface state (e.g. topologically protected). Moreover, another surprising consequence of the model proposed here is that it infers existence of enhanced surface conductivity that can be even several orders of magnitude greater than the bulk one, what is in fact, qualitatively the same situation as expected for a Kondo topological insulator state in SmB₆.

Relatively higher surface conductivity of SmB₆ can be according to the proposed model explained as follows. Direct consequence of (20) is that hopping probability exponentially decreases with increase of hop distance R^* . Typical hop distance in bulk, R_{bulk}^* , can differ from that of the surface, R_{surf}^* , if bulk and surface concentration of lattice imperfections playing role of hopping centers are different. It is well known that low temperature properties

of SmB₆ change significantly from sample to sample, indicating important role played by uncontrolled defects, i.e. impurities (typically 10⁻⁵ to 10⁻⁴ in atomic concentrations), small departures from stoichiometry, and structural point defects [11, 41]. Experimental results indicate that a typical distance between lattice imperfections in high-quality SmB₆ can be several orders of magnitude greater than the lattice parameter, i.e. $R_{bulk}^* \gg a(\text{SmB}_6)$. However, situation has to be completely different on the surface, because of much greater concentrations of lattice imperfections. The reason is not only “more damaged” surface layer, but also the fact that SmB₆ surface is “covered” by unterminated B- and Sm- bonds, which might play role of hopping centers. Considering $R_{surf}^* < R_{bulk}^*$, or even $R_{surf}^* \ll R_{bulk}^*$, and taking into account proportionality (20) it can be reasonably expected that hop probability in the surface layer can reach values in orders of magnitude greater than those in the bulk. Moreover, for completeness of the discussion it should be mentioned that because of relatively less values of R_{surf}^* and not excluded existence of localized surface states with a localization length, α_{surf}^{-1} , greater than one in bulk, it may arise situation that parameter $p = 3/2\alpha_{surf}R_{surf}^*$ will satisfy the condition $p \geq 1$. In such hypothetical case the value $3/2\alpha_{surf}R_{surf}^*$ will maximize (17), so that VFs-induced hop probability on the surface will be not expressed by (20), but will be proportional to

$$P_{surf}^* \propto \nu_{vf}^*/(\alpha_{surf}R_{surf}^*)^3, \quad (21)$$

what however, indicates a different electrical transport regime. Nevertheless, no matter whether hopping probability in the surface layer of SmB₆ is described by (20) or (21) (or even by combination of both of them because of presence of several types of localized surface states) it can be qualitatively concluded that hop probability in the surface layer is relatively greater than in bulk and it is temperature non-activated, i.e. metallic-like. Thus, the proposed scenario is qualitatively consistent with experimental studies of surface transport in SmB₆ [32–34] which have demonstrated metallic surface and insulating bulk separation, as well as studies of SmB₆ thin-films, which show systematic decrease of the resistivity and of the $\rho(4.2\text{ K})/\rho(300\text{ K})$ ratio with decreasing thin-film thickness [46]. It should be also emphasized that high surface conductivity of SmB₆ can be, in principle, a result of combination of several types of conduction mechanisms in surface layer [36], and here proposed VFs-induced hopping mechanism can be only one of them.

Similar scenario of temperature non-activated hopping type conduction as we propose

for SmB_6 is expected to be present also in other semiconducting valence-fluctuating systems with IB(s) and Fermi energy lying in the IB. For instance, qualitatively similar resistivity behavior to one of SmB_6 was observed also in FeSi [43–45] and YbB_{12} [2, 10]. In fact, resistivity/conductivity saturation at lowest temperatures should be a native property (a “fingerprint”) of many “real” VF semiconductors, because impurity states (lattice imperfections) are as a rule introduced during the preparation process of these materials.

In summary, we have provided arguments that presence of valence fluctuations in semiconducting systems having localized in-gap states (impurity band) introduced via lattice imperfections causes corresponding fluctuation of the energy of these states. Consequently, if the Fermi energy lies in the impurity band, energies of in-gap states laying in a certain vicinity of the Fermi energy fluctuate above and below Fermi energy, what creates favorable conditions for hops to empty states of less energy, i.e. without need of activation energy. This give rise to temperature non-activated hopping process with the hop probability governed by dynamics of VFs and concentration of hopping centers. The proposed mechanism is in excellent qualitative agreement with many experimental observations indicating close relationship between concentration of lattice imperfections and residual metallic-like conductivity of SmB_6 at lowest temperatures, thus brings possible explanation of unusual metallic like transport in SmB_6 (and related Kondo insulators). Moreover, because of the fact that (significantly) increased concentration of lattice imperfections that may play role of hopping centers is expected in the surface layer, it predicts strong enhancement of surface conductivity in SmB_6 . In this sense the proposed scenario, which utilizes the well established concept of hopping conduction in solids, enables to explain bulk and surface metallic-like properties of SmB_6 within common mechanism for bulk and surface conduction, i.e. without need to consider “unusual” metallic surface conduction, like existence of topologically protected surface. Nevertheless, question about quantitative conductivity estimation in SmB_6 (both bulk and surface) due to VFs-induced hopping process and a possible interplay of distinct types of surface conduction in SmB_6 remains open and requires further studies.

This work was supported by the Slovak Scientific Agency VEGA (Grant No. VEGA 2-0184-13).

[1] P. S. Riseborough, *Advances in Physics* **49**, 257 (2000).

- [2] P. Wachter, in *Intermediate Valence and Heavy Fermions*, (Handbook on the Physics and Chemistry of Rare Earths, vol.19, North Holland, 1993).
- [3] V. N. Antonov, B. N. Harmon, and A. N. Yaresko, *Phys. Rev. B* **66**, 165209 (2002).
- [4] T. Travaglini and P. Wachter, *Phys. Rev. B* **29**, 893 (1984).
- [5] T. Namba, H. Ohta, M. Motokawa, S. Kimura, S. Kunii, and T. Kasuya, *Physica B* **186-188** 440 (1993).
- [6] H. Ohta, R. Tanaka, M. Motokawa, S. Kunii, and T. Kasuya, *J. Phys. Soc. Jpn.* **50** 1361 (1991).
- [7] P. A. Alekseev, V. N. Lazukov, R. Osborn, B. D. Rainford, I. P. Sadikov, E. S. Konovalova, Yu. B. Paderno, *Europhys. Lett.* **23**, 347 (1993).
- [8] L. Frankowski and P. Wachter, *Solid State Commun.* **41**, 577 (1982).
- [9] M. Batkova, I. Batko, E. S. Konovalova, N. Shitsevalova, Y. Paderno, *Acta Phys. Pol. A* **113** 255 (2008).
- [10] M. Batkova, I. Batko, E. S. Konovalova, N. Shitsevalova, Y. Paderno, *Physica B* **378-380** 618 (2006).
- [11] J. C. Nickerson, R. M. White, K. N. Lee, R. Bachmann, T. H. Geballe, and G. W. Hull Jr., *Phys. Rev. B* **3**, 2030 (1971).
- [12] J. W. Allen, B. Batlogg, and P. Wachter, *Phys. Rev. B* **20**, 4807 (1979).
- [13] I. Baťko, P. Farkašovský, K. Flachbart, E. S. Konovalova, and Yu. B. Paderno, *Solid State Commun.* **88**, 405 (1993).
- [14] J. C. Cooley, M. C. Aronson, Z. Fisk, and P. C. Canfield, *Phys. Rev. Lett.* **74**, 1629 (1995).
- [15] K. Flachbart, S. Gabáni, E. Konovalova, Y. Paderno, and V. Pavlík, *Physica B* **293**, 417 (2001).
- [16] S. Gabáni, K. Flachbart, E. Konovalova, M. Orendáč, Y. Paderno, V. Pavlík, and J. Šebek, *Solid State Commun.* **117**, 641 (2001).
- [17] S. Gabáni, E. Bauer, S. Berger, K. Flachbart, Y. Paderno, C. Paul, V. Pavlík, and N. Shitsevalova, *Phys. Rev. B* **67**, 172406 (2003).
- [18] J. M. Tarascon, Y. Isikawa, B. Chevaliere, J. Etorneau, P. Hagenmuller, and M. Kasaya, *J. de Phys.* **41**, 1141 (1980).
- [19] R. L. Cohen, M. Eibschutz, K. W. West, and E. Buller, *J. Appl. Phys.* **41**, 898 (1970).
- [20] O. Peña, D. E. MacLaughlin, M. Lysak, and Z. Fisk, *J. Appl. Phys.* **52**, 2152 (1981).

- [21] E. Zirngiebl, S. Blumenroder, R. Mock, and G. Güntherodt, JMMM **54-57**, 359 (1986).
- [22] R. Mock, E. Zirngiebl, B. Hillebrands, G. Güntherodt, and F. Holtzberg, Phys. Rev. Lett. **57**, 1040 (1986).
- [23] Z. Fisk, J. L. Sarrao, S. L. Cooper, P. Nyhus, G. S. Boehinger, A. Passner, and P. C. Canfield, Physica B **223-224** 409 (1996).
- [24] T. Caldwell, A. P. Reyes, W. G. Moulton, P. H. Kuhns, M. J. R. Hoch, P. Schlottmann, and Z. Fisk, Phys. Rev. B **75**, 075106 (2007).
- [25] H. Miyazaki, T. Hajiri, T. Ito, S. Kunii, and S. Kimura, Phys. Rev. B **86**, 075105 (2012).
- [26] P. P. Edwards, R. L. Johnston, C. N. R. Rao, D. P. Tunstall, and F. Hensel, Phil. Trans. R. Soc. Lond. A **356**, 5 (1998).
- [27] A. F. Ioffe and A. R. Regel, Prog. Semicond. **4**, 237 (1960).
- [28] N. F. Mott and E. Davis in *Electronic Processes in Non-Crystalline Materials* (Clarendon Press, Oxford, 1971).
- [29] M. Dzero, M. Sun, K. Galitski, and P. Coleman, Phys. Rev. Lett. **104**, 106408 (2010).
- [30] M. Dzero, M. Sun, P. Coleman, and K. Galitski, Phys. Rev. B **85**, 045130 (2012).
- [31] F. Lu, J.Z. Zhao, H. Weng, and Xi. Dai, Phys. Rev. Lett. **110**, 096401 (2013).
- [32] D. J. Kim, T. Grant, and Z. Fisk, Phys. Rev. Lett. **109**, 096601 (2012).
- [33] S. Wolgast, C. Kurdak, K. Sun, J. W. Allen, Dae-Jeong Kim, and Z. Fisk, Phys. Rev. B **88**, 180405(R) (2013).
- [34] D. J. Kim, S. Thomas, T. Grant, J. Boltimer, Z. Fisk and JingXia, Sci. Rep. **3**, 3150 (2013).
- [35] Z.-H. Zhu, Phys. Rev. Lett. **111**, 216402 (2013).
- [36] F. Chen, C. Shang, A. F. Wang, X. G. Luo, T. Wu, and X. H. Chen, arXiv:1309.2378v2.
- [37] N. F. Mott, J. Non-Cryst. Solids, **1**, 1 (1968).
- [38] B. I. Shklovskii and A. L. Efros in *Electronic Properties of Doped Semiconductors*, (Springer Series in Solid State Sciences, 1984).
- [39] A. Miller, and E. Abrahams, Phys. Rev. B **4**, 2612 (1971).
- [40] V. Ambegaokar, B. I. Halperin, and J. S. Langer, Phys. Rev. **120**, 745 (1960).
- [41] J. Morillo, C.H. de Novion, Solid State Commun. **48**, 315 (1983).
- [42] See A.R. Long in *Hopping Transport in Solids*, Modern Problems in Condensed Matter Sciences, **28**, 207-231 (1991), and references therein.
- [43] M. B. Hunt, M. A. Chernikov, E. Felder, H. R. Ott, Z. Fisk, and P. Canfield, Phys. Rev. B

50, 14933 (1994).

- [44] S. Paschen, E. Felder, M. A. Chernikov, L. Degiorgi, H. Schwer, H. R. Ott, D. P. Young, J. L. Sarrao, and Z. Fisk, *Phys. Rev. B* **56**, 12916 (1997).
- [45] L. Degiorgi, M. Hunt, H. R. Ott, and Z. Fisk, *Physica B* **206-207**, 810 (1995).
- [46] I. Batko, K. Flachbart, J. Miškuf, V. M. Filipov, E. S. Konovalova, Ju. B. Paderno, J. Less-Common Met. **158** L17 (1990).