

Preserving Speaker Information in Direct Speech-to-Speech Translation with Non-Autoregressive Generation and Pretraining

Rui Zhou^{a,*}, Akinori Ito^a and Takashi Nose^a

^aGraduate School of Engineering, Tohoku University, Sendai, 9808579, Japan

ARTICLE INFO

Keywords:

Speech-to-Speech-Translation
Pretrain
Speaker information preservation
Non-autoregressive

ABSTRACT

Speech-to-Speech Translation (S2ST) refers to the conversion of speech in one language into semantically equivalent speech in another language, facilitating communication between speakers of different languages. Speech-to-Discrete Unit Translation (S2UT), a mainstream approach for end-to-end S2ST, addresses challenges such as error propagation across modules and slow inference speed often encountered in traditional cascade systems. However, as discrete units primarily capture content information, conventional S2UT methods fail to retain speaker-specific characteristics from the source.

Our previous work, SC-S2UT, introduced a speaker adapter and a unit-to-mel structure, enabling the preservation of speaker information and non-autoregressive speech generation. Building on this foundation, this study proposes a self-supervised pretraining method to enrich the information extracted by both the speaker adapter and the unit-to-mel structure. Additionally, we investigate different feature fusion strategies to further improve the integration of speaker and content features.

Experiments conducted on the CVSS-T dataset for ES-EN and FR-EN tasks demonstrate that our proposed method achieves a BLEU score improvement of 1.14 compared to SC-S2UT, along with significant enhancements in MOS and speaker similarity. Furthermore, our approach achieves translation quality comparable to traditional S2UT, with only a minimal increase of 0.04s per utterance in inference time, while maintaining high speaker similarity. These results validate the effectiveness of the proposed method.

1. Introduction

Speech has always been the most convenient and natural means of communication for humans. However, with over 6000 languages globally and hundreds commonly in use, communication between speakers of different languages can be challenging. Learning multiple languages to facilitate such interactions requires significant time and effort, making Speech-to-Speech Translation (S2ST) a highly valuable area of research.^{1 2} Traditionally, S2ST has been implemented using a cascade system. This approach involves three sequential steps: (1) Automatic Speech Recognition (ASR) to convert the source speech into text[7], (2) Machine Translation (MT) to translate the source text into the target language[5], and (3) Text-to-Speech (TTS) synthesis to generate target speech from the translated text[23]. Recent advancements have introduced integrated approaches that combine ASR and MT into a single Speech Translation module, thereby reducing one of the stages in the cascade[1]. However, cascade systems face significant challenges, the most critical being error propagation. Any error in one module (e.g., ASR, MT, or TTS) is compounded, deteriorating the final translation output. Moreover, the long inference time of these systems limits their practicality in real-time applications, hindering their widespread adoption for everyday use.

As a strategy to the limitations of cascade systems, End-to-End (E2E) systems have been proposed and are gaining traction. Translatotron was the first E2E S2ST model, employing a sequence-to-sequence architecture to directly generate target mel-spectrograms from source mel-spectrograms[13]. It also introduced auxiliary recognition for multitask learning, ensuring the encoder could effectively extract acoustic features from the source speech. This approach improved the translation accuracy by preserving essential information throughout the process. Building on this foundation, Translatotron2 enhanced the original model by incorporating an auxiliary recognition decoder during inference[11]. This addition provided additional usable information for speech generation, resulting in improved translation quality. Further advancements were made with Translatotron3, which extended the capabilities of its predecessor by combining techniques such as masked autoencoders, unsupervised embedding mapping, and back-translation. These innovations enabled Translatotron3 to perform unsupervised S2ST, pushing the boundaries of E2E systems by improving robustness and translation accuracy in low-resource scenarios[18]. The Translatotron series primarily focuses on generating the spectrogram of the target speech. In contrast, the speech-to-discrete unit (S2UT) framework adopts a different approach, aiming to produce quantized speech representations corresponding to the target speech.

The method introduced in [15] was the first to propose the S2UT framework. It utilizes a pretrained HuBERT model to extract speech representations for the target language and applies k-means clustering to quantize these representations into discrete units[8]. During model training, a transformer

*Corresponding author

✉ zhou.rui.p1@dc.tohoku.ac.jp (R. Zhou); aito.spcom@tohoku.ac.jp (A. Ito); takashi.nose.b7@tohoku.ac.jp (T. Nose)

ORCID(s): 0009-0001-3573-7905 (R. Zhou)

¹Demo page: <https://zhouruitohoku99.github.io/scs2ut-demo/>

²Code available at: <https://github.com/ZhouRuiTohoku99/SC-S2UT>

encoder-decoder architecture is employed to map the input speech to discrete units in the target language. Subsequently, a unit vocoder converts these discrete units into speech. This approach has demonstrated superior performance due to the discrete units containing primarily content information, which reduces noise and increases the clarity of the generated speech. However, precisely because discrete units only encode content, they lack speaker-specific information. Consequently, traditional S2UT systems can only synthesize speech in a generic voice and fail to retain the speaker's unique characteristics.

To address the issue of preserving speaker information in S2UT systems, two primary approaches have been proposed. The first involves using voice conversion techniques to transform the generated speech into the acoustic characteristics of the source speaker after the S2UT model has produced the target speech. However, this approach has notable drawbacks. It often performs poorly with unseen speakers, and it reintroduces a cascade structure, increasing inference time and defeating the purpose of E2E S2ST. Thus, designing an S2ST model that inherently generates speech containing both content and speaker information remains the ultimate goal. For instance, [29] proposed a method that generates an acoustic unit with speaker information alongside the content unit during the S2UT process. These units are then combined using an acoustic language model to produce the target acoustic unit, which is later converted into speech by a vocoder. However, this method suffers from several limitations: it requires a large number of parameters, and the acoustic language model relies on autoregressive generation, significantly increasing inference time.

In our previous work, we introduced the Speaker Retention Unit-to-Mel (SR-UTM) method, which uses a non-autoregressive approach to combine content units with speaker information[32]. Although this method improves inference speed, the quality of the generated speech was not optimal. So, in this work we address these shortcomings. The contributions of this work follows: (1) We utilize a pretraining strategy to separately train the speaker adapter and the unit-to-mel structure using self-supervised learning methods. These components are later fine-tuned together. Experimental results show that pretraining significantly enhances performance. (2) We incorporate pretrained speaker embeddings to directly extract speaker vectors during model training. This approach effectively improves speaker similarity, although it sacrifices some naturalness in the generated speech. (3) We explore various feature fusion methods to integrate speaker information with content units, rigorously testing their effectiveness.

The remainder of this paper is structured as follows: Section 2 introduces related work. Section 3 describes the proposed methods, including the pretraining process and different feature fusion strategies. Section 4 details our experiments, evaluation metrics, and baseline methods. Section 5 presents experimental results and analysis. Section 6 discusses future work, and concludes the paper.

2. Related Work

2.1. Direct S2UT System

Lee et al. were the first to propose utilizing discrete units obtained from speech representation clustering as translation targets for speech-to-speech translation[15]. Subsequently, they observed significant variability in the generated units when different speakers uttered the same sentence[16]. To address this, they introduced a speech unit normalization method, which standardizes the speech units across different speakers, thereby improving the accuracy of S2UT. Hirofumi et al. proposed UnitY, an efficient two-pass direct S2ST model that generates both textual and discrete unit outputs. This model predicts subwords in the first pass, bridges decoder representations with an additional encoder, and employs deep-shallow two-pass decoders, leading to enhanced accuracy[10]. Furthermore, [31, 3] presented a speech-to-speech translation framework for unwritten languages that does not rely on target language text. Using Hokkien and English datasets, their approach demonstrated strong performance. Popuri et al. utilized a pre-trained wav2vec model in place of a Transformer encoder to extract acoustic features for training the S2UT model enhanced the performance[21]. Huang et al. proposed a bilateral perturbation method, which filters out rhythm, pitch, energy, and other prosodic features from speech, extracting only content-related units. They were also the first to introduce a non-autoregressive S2UT model, which improved the quality of S2UT while significantly enhancing translation speed[9]. Similarly, Fang et al. employed a Directed Acyclic Transformer, another non-autoregressive model, to further improve both the overall translation speed and quality[6].

2.2. Speaker information preservation

In the field of TTS, a speaker encoder is often employed to capture speaker-specific information, enabling the generation of speech that retains speaker identity. Similarly, in the domain of S2ST, Translatotron introduced a speaker encoder to extract speaker features, which were then combined with acoustic features to produce target speech that preserves speaker information[13].

In the context of S2UT, Wang et al. proposed using residual vector quantization to extract speaker acoustic units. These units were then combined with content units through an acoustic language model to generate target acoustic units with speaker information, achieving speaker-preserving S2UT[29]. Song et al. adopted a style adaptor to integrate speaker information with unit representations, using an acoustic decoder to produce speaker-preserving units[26].

Since mel spectrograms inherently contain richer speaker information, in our previous work, we proposed the SRU2M framework, which combines content units and speaker information to generate mel spectrograms in the target language. These spectrograms are then converted into speech using a vocoder, achieving excellent results.

However, in this work, we propose a novel approach, which will be detailed in the next section.

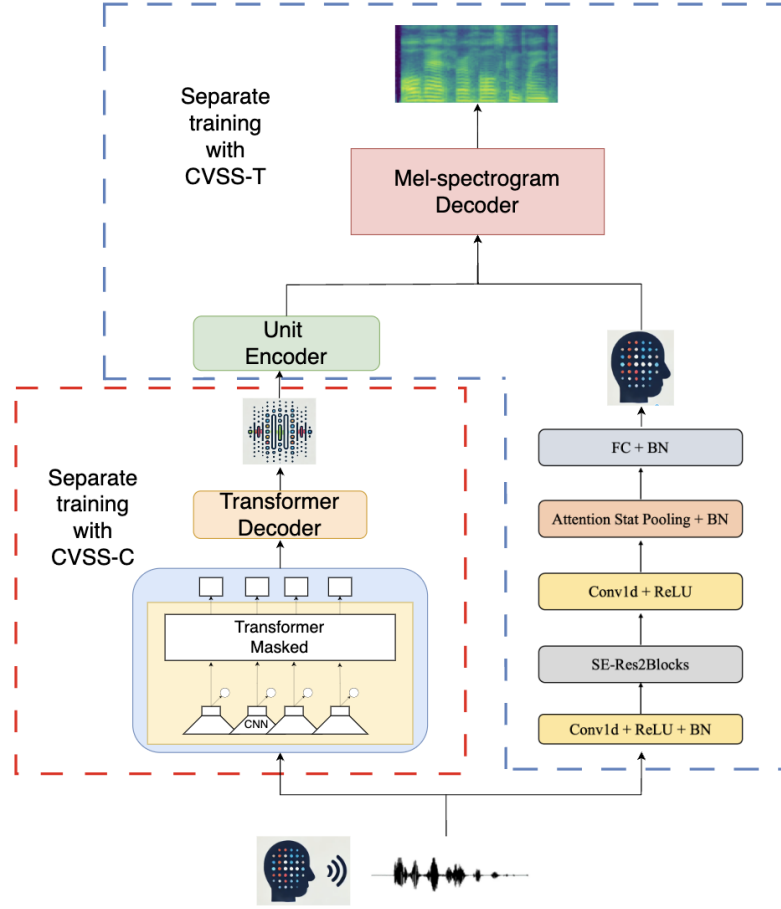

Figure 1: Speaker Retention Unit-to-Mel based Speaker Consistency S2UT

3. Method

3.1. Previous literature

Figure 1 illustrates our previous Speaker Retention Unit to Mel (SR U2M)-based SC-S2UT model. As depicted, the components within the red dashed box and the blue dashed box are trained separately.

First, the components within the red dashed box are based on part of the S2UT structure proposed in[21]. A pre-trained wav2vec 2.0 model is utilized to extract acoustic features from the source speech, which are then fed into a Transformer decoder to generate discrete units corresponding to the target speech.

Second, the components within the blue dashed box depict the training process of SR U2M. The ECAPA-TDNN speaker encoder architecture is employed to extract speaker information[4], while a unit encoder is used to extract unit features. These features are combined and input into a mel-spectrogram generator, producing a mel-spectrogram of the target language that retains the source speaker’s characteristics. However, it can be observed that in our previous work, we used the CVSS-C corpus to train the S2UT module.

In the CVSS-C corpus, the source languages (e.g., Spanish, French) are multi-speaker speech, whereas the corresponding target English speech is single-speaker (a female voice)[12]. In contrast, when training the SU2M module, we utilized the CVSS-T corpus. While the source languages remain as multi-speaker speech, the target speech was synthesized as multi-speaker speech using multi-speaker TTS.

This approach introduces two significant drawbacks. First, since the S2UT module generates single-speaker units, while SRU2M is trained on multi-speaker units, discrepancies arise. As highlighted in [16], the discrete units corresponding to different speakers can vary, leading to inference errors. Second, during SRU2M training, the generated mel-spectrogram of the target English speech deviates from the true voice characteristics of the source speaker. This mismatch results in the translated speech being more similar to the target speech than to the source speech, as also noted in the conclusions of [3]. To address these issues, we propose leveraging a self-supervised pretraining method.

3.2. Self-supervised Pretraining

Our SR U2M consists of three main components. The first is the unit encoder, which extracts the target content unit

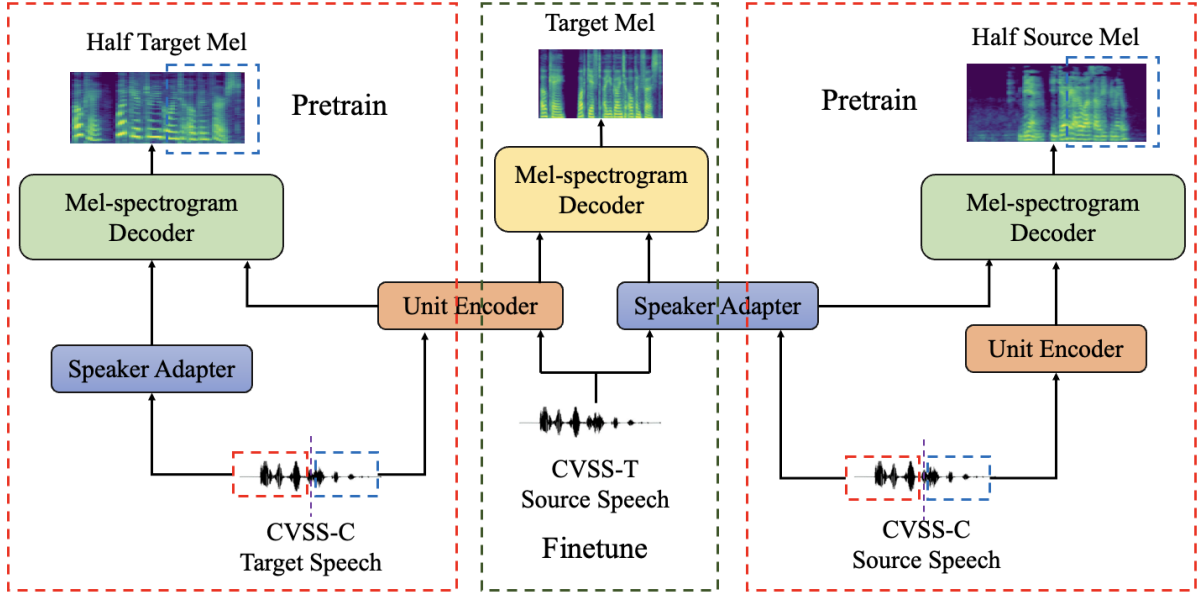

Figure 2: Illustration of the workflow for the self-supervised pretrain and finetune

features. The second is the speaker adapter, responsible for extracting the source speaker’s embedding. The third is the mel-spectrogram decoder, which integrates the unit features and speaker embeddings to generate the mel-spectrogram.

To optimize the training process, we pretrain these components separately. The workflow is illustrated in Figure 2.

As shown in Figure 2, the module in red dashed box shows the pretrain phase, we first divide the source waveform into two halves. The first half of the waveform is fed into the speaker adapter to extract the source speaker’s embedding. The discrete units of the second half of the waveform are extracted and passed through the unit encoder. The mel-spectrogram decoder then combines the unit features and speaker embedding to generate the mel-spectrogram for the second half. We train this process using multi-speaker source data in Spanish and French. The goal is for the speaker adapter to learn how to extract the source speaker’s embedding effectively. Subsequently, we use the same approach to split the target waveform (single-speaker English data) into two halves. This part is trained to ensure the unit encoder learns to extract sufficient content features from single-speaker discrete units.

By adopting this method, the speaker adapter learns to extract source speaker embeddings, and the unit encoder is trained to capture content features from single-speaker units. Importantly, this training process is self-supervised, requiring no paired data. However, the mel-spectrogram decoder pretrained with this method may struggle to adapt effectively across languages. To address this, we fine-tune the model using the CVSS-T corpus, leveraging the pretrained parameters of the unit encoder and speaker adapter, while randomly initializing the parameters of the mel-spectrogram decoder.

3.3. Training with Speaker Embedding

We observed that since our goal is for the speaker adapter to focus solely on extracting speaker information while ignoring language and content, we could leverage pretrained cross-lingual speaker adapters from other fields, such as speaker verification or speaker classification. These adapters can directly provide speaker embeddings for use as the speaker vector during both training and inference.

To validate this hypothesis, we employed a pretrained GE2E model as described in [27] to extract speaker embeddings. Before training, we followed the workflow introduced in Resemblyzer³ to extract the speaker embedding from the first half of the source waveform. This embedding was then passed through a linear layer and combined with the output of the unit encoder for the second half of the waveform. The resulting features were fed into the mel-spectrogram decoder to generate the target mel-spectrogram for the second half. During the inference phase, we directly extract the speaker embedding from the source speech using Resemblyzer. This embedding is then combined with the output of the S2UT module to generate the target mel-spectrogram. In addition, we applied a speech enhancement method to improve the fluency of the generated speech. Specifically, we utilized the DeepFilter model[25], which enhances speech quality without imposing additional computational burden on inference time.

3.4. Feature Fusion

To facilitate effective integration of unit content features and speaker features, we explored three fusion strategies, as illustrated in Figure 3.

Cross-Attention (Figure 3a): This approach utilizes the multi-head attention mechanism, which operates with three

³<https://github.com/resemble-ai/Resemblyzer?tab=readme-ov-file>

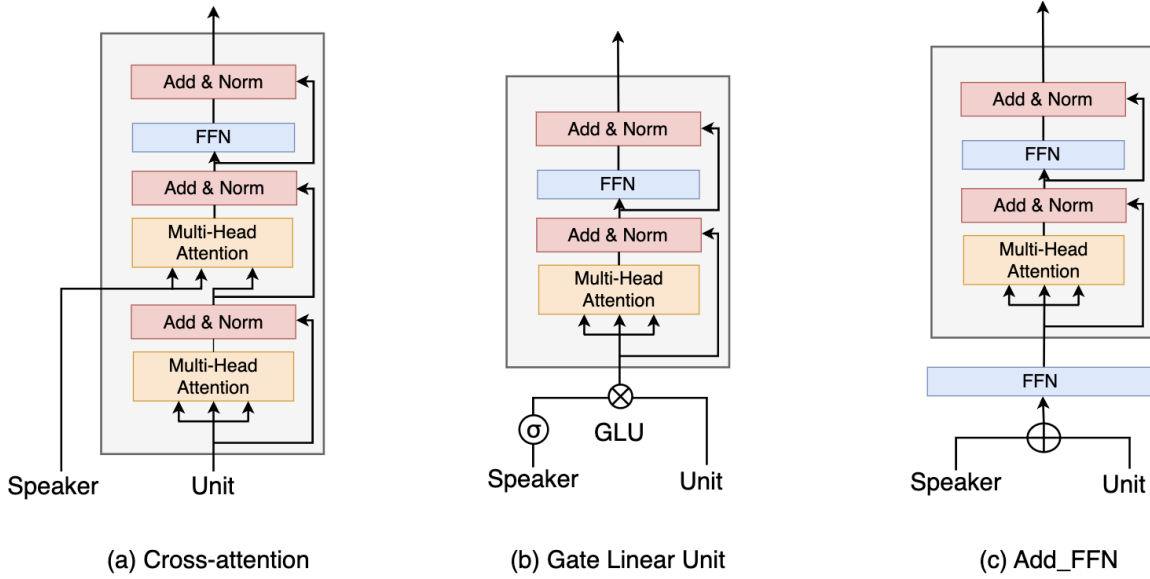

Figure 3: Illustration of different feature fusion methods

components: query, key, and value. Here, the content feature is designated as the query, while the speaker feature is used as both the key and value. This setup enables the content feature to focus on specific aspects of the speaker feature, allowing for adaptive feature fusion based on learned attention weights.

Gated Linear Unit (GLU) (Figure 3b): GLU is a mechanism designed to regulate the flow of information between different features. It selectively allows relevant features to pass while suppressing less useful ones, enabling more efficient feature interaction. In our design, the content feature is placed at the beginning of the input sequence, followed by the speaker feature. The speaker feature acts as a gate to modulate the content feature, ensuring a balanced integration of content and speaker information.

Add_FFN (Figure 3c): This method fuses features by element-wise addition of the content and speaker features, followed by a feed-forward network (FFN). The FFN reduces the dimensionality of the combined feature, applies a non-linear activation function, and then restores the original dimensionality, enabling effective processing of the fused representation.

Each method was evaluated to determine its effectiveness in achieving a cohesive integration of the content and speaker information for generating accurate mel-spectrograms.

4. Experiments

4.1. Dataset

We conducted our experiments using the CVSS corpus for Spanish-to-English (ES-EN) and French-to-English (FR-EN) translation tasks. In the training phase, the CVSS-C corpus was utilized to train the S2UT model. For the

proposed self-supervised pretraining stage, we performed pretraining separately using the CVSS-C Spanish corpus. Subsequently, we fine-tuned the model using the CVSS-T corpus for both Spanish and French. In the testing phase, we evaluated the model on the test data. However, for testing inference time, instead of using the full FR-EN test dataset, we categorized the test samples into five duration-based intervals: 0–3 seconds, 3–5 seconds, 5–7 seconds, 7–9 seconds, and over 9 seconds. Each interval contained 200 audio samples, resulting in a total of 1,000 audio samples. For experiments involving different feature fusion methods, we restricted the evaluation to the ES-EN task. Detailed data information are presented in Table 1.

4.2. System Implementation

4.2.1. Speaker Preservation S2UT Model

We used the pre-trained HuBERT model⁴, trained on the LibriSpeech dataset[19], and performed k-means clustering with $K=100$ on the sixth-layer representations to extract discrete units. Additionally, we employed the pre-trained wav2vec model to extract acoustic features from the source waveform. For Spanish⁵, the model was trained on the unlabeled VoxPopuli corpus subset[28], and for French⁶, it was trained on 14K hours of French speech data[20].

Building on this, we introduced multi-task learning with auxiliary speech recognition. Specifically, we passed the intermediate outputs of the decoder through a softmax layer and computed a CTC loss with the target English transcriptions. Since auxiliary speech recognition results are not required during inference, this approach does not increase the inference time.

⁴<https://github.com/facebookresearch/fairseq/tree/main/examples/hubert>

⁵<https://github.com/facebookresearch/voxpopuli/>

⁶<https://huggingface.co/LeBenchmark/wav2vec2-FR-14K-large>

Table 1

Statistics (number of samples and duration) of the CVSS Spanish-English and France-English dataset

	CVSS-C					CVSS-T				
	Es-En		Fr-En			Es-En		Fr-En		
	train	test	train	test	time-test	train	test	train	test	time-test
# samples	79k	13.2k	20.7k	14.7k	1k	79k	13.2k	20.7k	14.7k	1k
source (hrs)	113.1	22.7	264.3	23.3	1.79	113.1	22.7	265.3	23.3	1.79
target (hrs)	69.5	12.4	174	13.3	0.93	73.7	13.3	192.7	15.0	1.08

Table 2

Hyperparameters for Speaker Preservation S2UT

Hyperparameter		SC-S2ST
S2UT Decoder	Unit neurons	103
	Decoder Block	6
	Decoder Hidden	512
	Encoder Attention Heads	8
	Encoder Dropout	0.1
SR-U2M Unit-Encoder Mel-Decoder	Encoder Block	6
	Decoder Block	6
	Encoder Kernel Hidden	31
	Attention Heads	512
	Dropout	8
Speaker Adapter	Channels	[1024, 1024, 1024, 1024, 3072]
	Kernel Sizes	[5, 3, 3, 3, 1]
	Dilations	[1, 2, 3, 4, 1]
	Groups	[1, 1, 1, 1, 1]
	Attention Channels	128
GE2E	Hidden	256
	Embedding	256
	Layers	3

For SR-U2M, we computed 80-dimensional melspectrogram features at every 20-ms interval, ensuring alignment with the length of the discrete units. The proposed self-supervised pretraining used the same model architecture and parameters in both the pretraining and fine-tuning stages. Additionally, in experiments involving pretrained speaker embeddings, we utilized the GE2E model for extracting the speaker representations[27]. The hyperparameters used in our model are presented in Table 2.

For waveform generation, we employ HiFi-GAN[14] as the vocoder⁷ and trained with multispeaker LibriTTS corpus[30].

4.2.2. Evaluation Metrics

We evaluate the proposed method across four dimensions: (1).Translation Accuracy: One of the most critical aspects of S2ST is ensuring the accuracy of the translation content. We evaluate this using the BLEU (Bilingual Evaluation Understudy) score, which measures the precision of n-gram matches (from 1-gram to 4-gram in our setup) between

⁷<https://huggingface.co/speechbrain/tts-hifigan-libritts-16kHz>

the generated text and the reference text. To compute BLEU scores, we first perform speech recognition on the translation output using a Transformer-based end-to-end ASR model, pre-trained on LibriSpeech, which achieved a WER of 2.27 on the test-clean set⁸. The recognized text is then compared against the reference text to calculate the BLEU score, which includes a brevity penalty (BP) to adjust for length differences between the generated and reference text. The final BLEU score is the weighted geometric mean of n-gram precision multiplied by the brevity penalty, providing an assessment of both accuracy and fluency. (2).Naturalness of Translation Speech: We assess the naturalness of the generated speech using the Mean Opinion Score (MOS). To reduce biases caused by external factors, such as tester distractions or environmental influences during evaluation, we employ UTMOS⁹, an automated MOS estimation method based on self-supervised learning as described in [24]. This objective evaluation aligns closely with human judgment, ensuring a robust assessment of naturalness. (3).Similarity Between Translation Speech and Source Speaker: This dimension evaluates whether our method successfully preserves the source speaker’s characteristics in the translation output. We first extract speaker embeddings from both the source speech and the translation speech using the method described in[27]. The cosine similarity between these embeddings is then calculated to quantify the similarity. (4). Inference Time: The efficiency of the model is a critical factor for its practical applicability. We measure the inference time from the extraction of features from the source speech to the generation of the translation speech. The average time taken across multiple samples is reported as the inference time. To contextualize the results, we compare the average inference time against the average duration of the source speech, which serves as the ground truth benchmark, inference time test were conducted on an NVIDIA RTX 3090 GPU. All our experiments were conducted using the SpeechBrain framework[22].

4.2.3. Baseline

We selected both cascade systems and end-to-end systems as baselines for comparison. For cascade baselines, we first chose a pretrained wav2vec-based S2UT model as the baseline for S2UT[21], as the discrete units used in our SR-U2M module are derived from this model. We compared

⁸<https://huggingface.co/speechbrain/asr-transformer-transformerlm-librispeech>

⁹<https://github.com/sarulab-speech/UTMOS22>

Table 3

Bleu Score and Mos Score and Similarity and Inference Time for our Experiment

	BLEU Score \uparrow		MOS Score \uparrow		Similarity \uparrow		Inference time(s/utt) \downarrow
	ES-EN	FR-EN	ES-EN	FR-EN	ES-EN	FR-EN	FR-EN
Cascade System							
S2UT[21]	18.01	24.02	3.31 ± 0.11	3.29 ± 0.12	/	/	0.796
S2UT + FreeVC[17]	17.68	23.53	4.20 ± 0.09	4.19 ± 0.10	0.581	0.592	1.574
ASR + MT + SpeakerTTS[3]	21.65	20.18	3.51 ± 0.09	3.54 ± 0.08	0.652	0.664	2.956
End-to-End System							
SC-S2UT[32]	16.10	21.68	3.26 ± 0.13	3.20 ± 0.11	0.609	0.611	0.813
Style-S2UT[5]	16.30	22.00	3.86 ± 0.06 *		0.73		**
Ours							
Embedding SC-S2UT							
ES	16.93	22.41	2.78 ± 0.08	2.84 ± 0.09	0.667	0.671	0.864
ES + Enhance	16.84	21.73	3.20 ± 0.08	3.21 ± 0.09	0.655	0.663	0.911
FR	16.86	22.37	2.70 ± 0.09	2.74 ± 0.08	0.670	0.682	0.864
FR + Enhance	16.79	21.31	2.97 ± 0.08	2.98 ± 0.09	0.661	0.677	0.911
Pretrain SC-S2UT							
ES	17.24	22.43	3.35 ± 0.06	3.30 ± 0.07	0.629	0.613	0.813
ES + Enhance	17.12	22.15	3.52 ± 0.08	3.47 ± 0.07	0.615	0.595	0.859
FR	17.16	22.82	2.87 ± 0.12	3.02 ± 0.11	0.574	0.621	0.813
FR + Enhance	16.75	22.44	3.09 ± 0.09	3.24 ± 0.08	0.575	0.619	0.859
Ground Truth	88.64	80.29	4.45 ± 0.11	4.44 ± 0.11	0.677	0.687	6.432

The results of * are derived from subjective experiments conducted by selected experimenters. Due to differences among experimenters, there may be biases in the outcomes. The value of ** was not measured and provided in original work

our method with this baseline in terms of BLEU score, MOS, and inference time. To evaluate speaker similarity, we employed the FreeVC[17] voice conversion method, which converts the waveform generated by S2UT into speech resembling the source speaker’s voice. Additionally, we used an ASR+MT+speaker voice preservation TTS cascade system as another baseline. For ASR, we used wav2vec 2.0 with CTC for both Spanish¹⁰ and French¹¹. For Machine Translation¹², a pretrained Transformer model was used for both languages. For Text-to-Speech (TTS), we leveraged YourTTS zero-shot multi-speaker tts model for English TTS[2].

For End-to-End baselines, we selected our previous SC-S2UT as the baseline for end-to-end systems. While there are other end-to-end S2ST models that preserve speaker voice, such as those proposed in [11] and [26], these models use different datasets, and their implementation codes are not publicly available. Therefore, we only compared our approach with Style-S2UT[29].

5. Results

5.1. Pretrain and Embedding Results

The results presented in Table 3 illustrate the effectiveness of our proposed methods compared to previous work, including SC-S2UT, state-of-the-art approaches such as Style-S2UT, and Cascade Systems.

BLEU Scores: Our Pretrain SC-S2UT achieves BLEU scores competitive with Cascade Systems. For example, Pretrain SC-S2UT (FR) achieves 22.82 for FR-EN, which is comparable to the S2UT baseline (24.02) and surpasses ASR + MT + SpeakerTTS (20.18). Compared to Style-S2UT and previous SC-S2UT, which achieves 22.00 and 21.68 for FR-EN, our approach demonstrates a slight improvement in BLEU scores while maintaining efficiency.

MOS: The MOS of Style-S2UT were obtained through subjective human evaluations, while our MOS scores were generated using an objective machine-based evaluation metric. Due to the differences in evaluation methodologies, a direct comparison between our methods and Style-S2UT is not feasible. However, when comparing our methods to the previous SC-S2UT, improvements can be observed even without speech enhancement. For example, Pretrain SC-S2UT achieves an MOS of 3.35 ± 0.06 (ES-EN) without enhancement, which surpasses SC-S2UT (3.26 ± 0.13). Additionally, our MOS scores are higher than those of the S2UT cascade system (3.31 ± 0.11 for ES-EN). The inclusion of speech enhancement further improves the MOS scores. For instance, Pretrain SC-S2UT (ES + Enhance) achieves an MOS of 3.52 ± 0.08 for ES-EN, which is comparable to the ASR + MT + SpeakerTTS system (3.51 ± 0.09). This demonstrates that our method not only improves over SC-S2UT and S2UT but also rivals the multi-stage ASR + MT + SpeakerTTS pipeline in naturalness, while maintaining the efficiency of an end-to-end system.

Similarity: Both the Pretrain SC-S2UT and Embedding SC-S2UT significantly outperform previous SC-S2UT and S2UT+Freevc (e.g., 0.629 vs. 0.609 and 0.581 for ES-EN in Pretrain SC-S2UT). Notably, our Embedding SC-S2UT even

¹⁰<https://huggingface.co/facebook/wav2vec2-large-xlsr-53-spanish>

¹¹<https://huggingface.co/facebook/wav2vec2-large-xlsr-53-french>

¹²<https://github.com/Helsinki-NLP/Tatoeba-Challenge/tree/master/models>

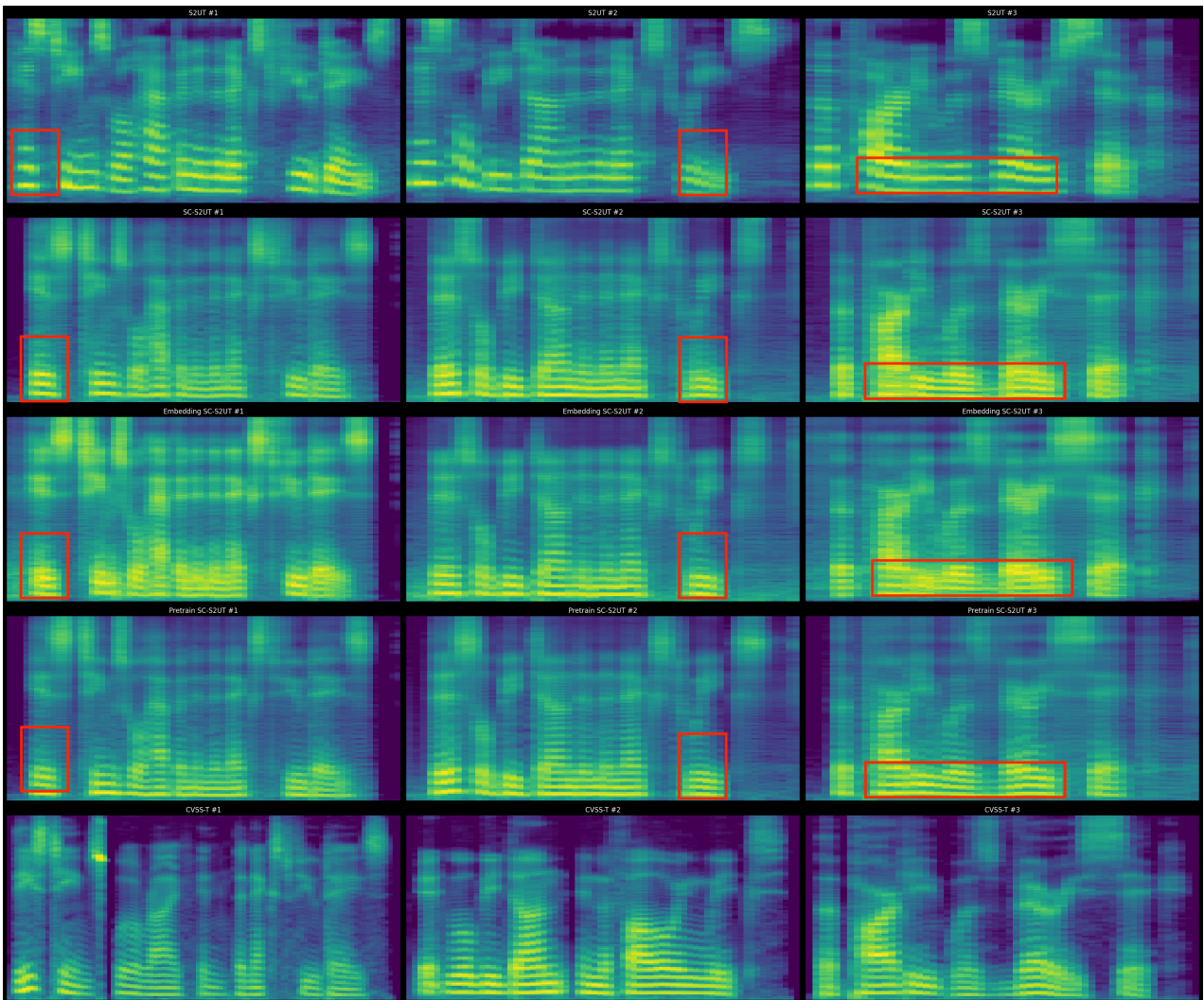

Figure 4: Mel-spectrogram of different methods generated waveforms

surpasses the ASR + MT + SpeakerTTS pipeline in speaker similarity (e.g., 0.682 vs. 0.664 for FR-EN) and approaches the ground truth values (0.687 for FR-EN). This highlights the ability of our embedding-based approach to effectively preserve speaker identity. However, our methods still fall slightly short of Style-S2UT, which achieves the highest speaker similarity (e.g., 0.73 for FR-EN).

Inference time: Our Pretrain SC-S2UT achieves an average inference time of 0.813 seconds per utterance, which is nearly identical to the original S2UT baseline (0.796 seconds). Even the Embedding SC-S2UT approach, which emphasizes speaker similarity, only increases inference time slightly to 0.864 seconds per utterance (+0.07 seconds). The addition of speech enhancement to Pretrain SC-S2UT leads to further improvements in MOS, with only 0.04s increase in inference time. Our methods significantly outperform cascade systems such as S2UT + FreeVC and ASR + MT + SpeakerTTS in inference efficiency, which are 1.574 seconds and 2.965 seconds per utterance. Style-S2UT does not report explicit inference time results, its paper mentions that the

method involves significant computational overhead due to its complex architecture and large model size.

Our two proposed methods, Embedding SC-S2UT and Pretrain SC-S2UT, exhibit complementary strengths that cater to different application needs. Embedding SC-S2UT excels in speaker similarity, achieving performance close to ground truth and surpassing many cascade systems, making it ideal for tasks prioritizing speaker identity preservation. On the other hand, Pretrain SC-S2UT delivers stronger overall performance in translation quality, naturalness, and inference efficiency, making it more suitable for scenarios where translation accuracy is crucial.

To further analyze the quality of synthesized speech, we randomly selected three waveforms generated by each method and extracted their corresponding Mel spectrograms, as shown in Figure 4. From top to bottom, the spectrograms represent the results of S2UT, previous SC-S2UT, embedding-based SC-S2UT, pretrain SC-S2UT, and the baseline CVSS-T system, respectively.

Table 4
Result of different feature fusion method

	BLEU Score \uparrow			MOS Score \uparrow			Similarity \uparrow		
	Attention	GLU	Plus+FFN	Attention	GLU	Plus+FFN	Attention	GLU	Plus+FFN
Embedding	16.93	16.18	15.97	2.78 ± 0.08	2.53 ± 0.09	2.62 ± 0.08	0.667	0.640	0.652
Pretrain	17.24	17.17	17.01	3.35 ± 0.06	3.19 ± 0.09	3.09 ± 0.09	0.629	0.607	0.591

The visual comparison of these spectrograms highlights significant differences in the richness of details and spectral structures across methods. Notably, the spectrograms generated by pretrain SC-S2UT exhibit more detailed structures, which reflects the system's ability to produce speech with higher naturalness.

5.2. Feature Fusion Result

In our task of speaker voice preservation for speech-to-speech translation, we tested different feature fusion methods to integrate speaker embedding information with unit content features. As shown in Table 4, the cross-attention mechanism consistently outperforms GLU and Plus+FFN in both the embedding-based and pretrain approaches.

This superior performance may be attributed to two main reasons. First, cross-attention provides dynamic alignment between speaker embedding and unit content features, enabling the model to selectively focus on the most relevant information for preserving speaker identity while maintaining accurate content generation. Second, cross-attention effectively models long-range temporal dependencies, which are critical for ensuring smooth integration of speaker-specific and linguistic features over time. In contrast, fixed transformation methods such as GLU and Plus+FFN lack the adaptability to fully capture these complex interactions, resulting in suboptimal fusion and degraded performance.

6. Conclusion and Future work

In this study, we proposed two approaches to optimize the previous SC-S2UT model. By incorporating self-supervised pretraining with fine-tuning and utilizing pre-trained speaker embeddings as the training and inference data, our methods achieved improvements over the baseline SC-S2UT in BLEU score, MOS, and speaker similarity. Additionally, compared to S2UT, our approach preserves speaker information without significantly increasing inference overhead, while also enhancing MOS to some extent. Furthermore, we evaluated three different feature fusion strategies and demonstrated that cross-attention effectively integrates speaker and content features. In the future, we plan to conduct experiments with SC-S2UT on other languages, including translation between linguistically diverse languages such as Chinese, Japanese, and English.

CRediT authorship contribution statement

Rui Zhou: Conceptualization of the study, methodology design, code implementation, experimental execution, results analysis, and manuscript writing. **Akinori Ito:** Validation of methodological feasibility, guidance on experiments, and manuscript revision. **Takashi Nose:** Offered suggestions on methodology, manuscript revision.

References

- [1] Bahar, P., Bieschke, T., Ney, H., 2019. A comparative study on end-to-end speech to text translation, in: 2019 IEEE Automatic Speech Recognition and Understanding Workshop (ASRU), IEEE, pp. 792–799.
- [2] Casanova, E., Weber, J., Shulby, C.D., Junior, A.C., Gölge, E., Ponti, M.A., 2022. Yourtts: Towards zero-shot multi-speaker tts and zero-shot voice conversion for everyone, in: International Conference on Machine Learning, PMLR, pp. 2709–2720.
- [3] Chen, P.J., Tran, K., Yang, Y., Du, J., Kao, J., Chung, Y.A., Tomasello, P., Duquenne, P.A., Schwenk, H., Gong, H., et al., 2022. Speech-to-speech translation for a real-world unwritten language. arXiv preprint arXiv:2211.06474 .
- [4] Desplanques, B., Thienpondt, J., Demuynck, K., 2020. Ecapa-tdnn: Emphasized channel attention, propagation and aggregation in tdnn based speaker verification. arXiv preprint arXiv:2005.07143 .
- [5] Devlin, J., 2018. Bert: Pre-training of deep bidirectional transformers for language understanding. arXiv preprint arXiv:1810.04805 .
- [6] Fang, Q., Zhou, Y., Feng, Y., 2023. Daspeech: Directed acyclic transformer for fast and high-quality speech-to-speech translation. Advances in Neural Information Processing Systems 36, 72604–72623.
- [7] Gulati, A., Qin, J., Chiu, C.C., Parmar, N., Zhang, Y., Yu, J., Han, W., Wang, S., Zhang, Z., Wu, Y., et al., 2020. Conformer: Convolution-augmented transformer for speech recognition. arXiv preprint arXiv:2005.08100 .
- [8] Hsu, W.N., Bolte, B., Tsai, Y.H.H., Lakhota, K., Salakhutdinov, R., Mohamed, A., 2021. Hubert: Self-supervised speech representation learning by masked prediction of hidden units. IEEE/ACM transactions on audio, speech, and language processing 29, 3451–3460.
- [9] Huang, R., Liu, J., Liu, H., Ren, Y., Zhang, L., He, J., Zhao, Z., 2022. Transpeech: Speech-to-speech translation with bilateral perturbation. arXiv preprint arXiv:2205.12523 .
- [10] Inaguma, H., Popuri, S., Kulikov, I., Chen, P.J., Wang, C., Chung, Y.A., Tang, Y., Lee, A., Watanabe, S., Pino, J., 2022. Unity: Two-pass direct speech-to-speech translation with discrete units. arXiv preprint arXiv:2212.08055 .
- [11] Jia, Y., Ramanovich, M.T., Remez, T., Pomerantz, R., 2022a. Translatotron 2: High-quality direct speech-to-speech translation with voice preservation, in: International Conference on Machine Learning, PMLR, pp. 10120–10134.
- [12] Jia, Y., Ramanovich, M.T., Wang, Q., Zen, H., 2022b. Cvss corpus and massively multilingual speech-to-speech translation. arXiv preprint arXiv:2201.03713 .
- [13] Jia, Y., Weiss, R.J., Biadsy, F., Macherey, W., Johnson, M., Chen, Z., Wu, Y., 2019. Direct speech-to-speech translation with a sequence-to-sequence model. arXiv preprint arXiv:1904.06037 .

- [14] Kong, J., Kim, J., Bae, J., 2020. Hifi-gan: Generative adversarial networks for efficient and high fidelity speech synthesis. *Advances in neural information processing systems* 33, 17022–17033.
- [15] Lee, A., Chen, P.J., Wang, C., Gu, J., Popuri, S., Ma, X., Polyak, A., Adi, Y., He, Q., Tang, Y., et al., 2021a. Direct speech-to-speech translation with discrete units. *arXiv preprint arXiv:2107.05604*.
- [16] Lee, A., Gong, H., Duquenne, P.A., Schwenk, H., Chen, P.J., Wang, C., Popuri, S., Adi, Y., Pino, J., Gu, J., et al., 2021b. Textless speech-to-speech translation on real data. *arXiv preprint arXiv:2112.08352*.
- [17] Li, J., Tu, W., Xiao, L., 2023. Freevc: Towards high-quality text-free one-shot voice conversion, in: *ICASSP 2023-2023 IEEE International Conference on Acoustics, Speech and Signal Processing (ICASSP)*, IEEE. pp. 1–5.
- [18] Nachmani, E., Levkovitch, A., Ding, Y., Asawaroengchai, C., Zen, H., Ramanovich, M.T., 2024. Translatotron 3: Speech to speech translation with monolingual data, in: *ICASSP 2024-2024 IEEE International Conference on Acoustics, Speech and Signal Processing (ICASSP)*, IEEE. pp. 10686–10690.
- [19] Panayotov, V., Chen, G., Povey, D., Khudanpur, S., 2015. Librispeech: an asr corpus based on public domain audio books, in: *2015 IEEE international conference on acoustics, speech and signal processing (ICASSP)*, IEEE. pp. 5206–5210.
- [20] Parcollet, T., Nguyen, H., Evain, S., Boito, M.Z., Pupier, A., Mdhaffar, S., Le, H., Alisamir, S., Tomashenko, N., Dinarelli, M., et al., 2024. Lebenchmark 2.0: A standardized, replicable and enhanced framework for self-supervised representations of french speech. *Computer Speech & Language* 86, 101622.
- [21] Popuri, S., Chen, P.J., Wang, C., Pino, J., Adi, Y., Gu, J., Hsu, W.N., Lee, A., 2022. Enhanced direct speech-to-speech translation using self-supervised pre-training and data augmentation. *arXiv preprint arXiv:2204.02967*.
- [22] Ravanelli, M., Parcollet, T., Plantinga, P., Rouhe, A., Cornell, S., Lugosch, L., Subakan, C., Dawalatabad, N., Heba, A., Zhong, J., Chou, J.C., Yeh, S.L., Fu, S.W., Liao, C.F., Rastorgueva, E., Grondin, F., Aris, W., Na, H., Gao, Y., Mori, R.D., Bengio, Y., 2021. SpeechBrain: A general-purpose speech toolkit. *arXiv:2106.04624*. *arXiv:2106.04624*.
- [23] Ren, Y., Hu, C., Tan, X., Qin, T., Zhao, S., Zhao, Z., Liu, T.Y., 2020. FastSpeech 2: Fast and high-quality end-to-end text to speech. *arXiv preprint arXiv:2006.04558*.
- [24] Saeki, T., Xin, D., Nakata, W., Koriyama, T., Takamichi, S., Saruwatari, H., 2022. Utmos: Utokyo-sarulab system for voicemos challenge 2022. *arXiv preprint arXiv:2204.02152*.
- [25] Schröter, H., Escalante-B., A.N., Rosenkranz, T., Maier, A., 2022. DeepFilterNet: A low complexity speech enhancement framework for full-band audio based on deep filtering, in: *ICASSP 2022 IEEE International Conference on Acoustics, Speech and Signal Processing (ICASSP)*, IEEE.
- [26] Song, K., Ren, Y., Lei, Y., Wang, C., Wei, K., Xie, L., Yin, X., Ma, Z., 2023. Styles2st: Zero-shot style transfer for direct speech-to-speech translation. *arXiv preprint arXiv:2305.17732*.
- [27] Wan, L., Wang, Q., Papir, A., Moreno, I.L., 2018. Generalized end-to-end loss for speaker verification, in: *2018 IEEE International Conference on Acoustics, Speech and Signal Processing (ICASSP)*, IEEE. pp. 4879–4883.
- [28] Wang, C., Riviere, M., Lee, A., Wu, A., Talnikar, C., Haziza, D., Williamson, M., Pino, J., Dupoux, E., 2021. Voxpopuli: A large-scale multilingual speech corpus for representation learning, semi-supervised learning and interpretation. *arXiv preprint arXiv:2101.00390*.
- [29] Wang, Y., Bai, J., Huang, R., Li, R., Hong, Z., Zhao, Z., 2023. Speech-to-speech translation with discrete-unit-based style transfer. *arXiv preprint arXiv:2309.07566*.
- [30] Zen, H., Dang, V., Clark, R., Zhang, Y., Weiss, R.J., Jia, Y., Chen, Z., Wu, Y., 2019. Libritts: A corpus derived from librispeech for text-to-speech. *arXiv preprint arXiv:1904.02882*.
- [31] Zhang, C., Tan, X., Ren, Y., Qin, T., Zhang, K., Liu, T.Y., 2021. Uwspeech: Speech to speech translation for unwritten languages, in: *Proceedings of the AAAI Conference on Artificial Intelligence*, pp. 14319–14327.
- [32] Zhou, R., Ito, A., Nose, T., . Applying speaker retention and unit-to-mel techniques for enhanced speaker consistency in speech-to-speech translation .

Rui Zhou received the B.S. degree in automation major from Nanjing University of Posts and Telecommunications, and the M.S. degree in communications engineering from Tohoku University. He is currently a Ph.D. candidate at the Department of Communications Engineering, Graduate School of Engineering, Tohoku University, Japan. His research mainly focus on speech to speech translation.

Akinori Ito (Member, IEEE) received the Ph.D. degree in engineering from Tohoku University, Japan, in 1991. He is currently a Professor of the Department of Communications Engineering, Graduate School of Engineering, Tohoku University, Japan. His research interests include foreign language teaching system, music information processing, spoken dialog system, audio processing and automatic speech recognition.

Takashi Nose received the Ph.D. degree in information processing from Tokyo Institute of Technology, Japan, in 2009. He is currently an Associate Professor of the Department of Communications Engineering, Graduate School of Engineering, Tohoku University, Japan. His research interests include multimedia information processing, music information processing, audio coding, speech dialog, automatic speech recognition, speech synthesis and audio information processing.