

# An Open Source Python Package to Simulate Micro Thermoelectric Generators

D. Beretta\*  
University of Zurich

December 8, 2024

## Abstract

This article presents an open-source Python package for simulating micro-thermoelectric generators, based on the work by D. Beretta et al. (Sustainable Energy Fuels, 2017). Featuring a user-friendly graphical user interface and robust computational capabilities, the tool is designed for use by scientists, researchers, and engineers to analyze and optimize device designs. The software calculates key performance metrics such as power, efficiency, electrical resistance, open circuit voltage, and short circuit current per unit of device area, based on the device design and material properties. The full source code is available for download on GitHub, enabling further customization.

Symbol	Description
$\alpha_p, \alpha_n$	Seebeck coefficients of p- and n-type materials ( $\text{V K}^{-1}$ )
$\alpha_{pn}$	Seebeck coefficient of a thermocouple ( $\text{V K}^{-1}$ )
$\sigma_p, \sigma_n$	Electrical conductivity of p- and n-type materials ( $\text{S m}^{-1}$ )
$\rho_p, \rho_n$	Electrical resistivity of p- and n-type materials ( $\Omega \times \text{m}$ )
$\rho_{pn}$	Average electrical resistivity of a thermocouple ( $\Omega \times \text{m}$ )
$\kappa_p, \kappa_n, \kappa_i$	Thermal conductivity of p-type, n-type and insulating materials ( $\text{W m}^{-1} \text{K}^{-1}$ )
$\pi_p, \pi_n$	Peltier coefficients of p- and n-type materials (V)
$\pi_{pn}$	Peltier coefficient of a thermocouple (V)
$zT$	Figure of merit (dimensionless)
$\dot{q}_h, \dot{q}_c$	Hot and cold heat fluxes ( $\text{W m}^{-2}$ )
$\dot{q}_{\pi,h}, \dot{q}_{\pi,c}$	Peltier heat fluxes at the hot and cold sides ( $\text{W m}^{-2}$ )
$\dot{q}_j$	Joule heat flux ( $\text{W m}^{-2}$ )
$h_{r,h}, h_{r,c}$	Heat transfer coefficients of the hot and cold reservoirs ( $\text{W/m}^2/\text{K}$ )
$h_{s,h}, h_{s,c}$	Heat transfer coefficients of the hot and cold substrates ( $\text{W/m}^2/\text{K}$ )
$h_{pni}$	Heat transfer coefficient of a thermocouple ( $\text{W/m}^2/\text{K}$ )
$T_{r,h}, T_{r,c}$	Temperatures of the hot and cold reservoirs (K)
$T_{s,h}, T_{s,c}$	Temperatures of the hot and cold substrates (K)
$T_h, T_c$	Temperatures at the hot and cold sides of a thermocouple (K)
$n$	Number of thermocouples per unit of device area ( $\text{m}^{-2}$ )
$A_p, A_n, A_i$	Area of p-type, n-type and insulating materials ( $\text{m}^2$ )
$l$	Thermocouple length (m)
$R_p, R_n$	Electrical resistance of p- and n-type materials ( $\Omega$ )
$R_{pn}$	Electrical resistance of a thermocouple ( $\Omega$ )
$R$	Electrical resistance of a $\mu\text{TEG}$ ( $\Omega$ )
$R_{load}$	Electrical resistance of the load ( $\Omega$ )
$f$	Fill factor (dimensionless)
$p$	Power generated per unit of device area ( $\text{W m}^{-2}$ )
$\eta$	Efficiency of conversion (dimensionless)
$v_{oc}$	Open-circuit voltage per unit of device area ( $\text{V m}^{-2}$ )
$v_{load}$	Voltage across the load per unit of device area ( $\text{V m}^{-2}$ )
$i_{sc}$	Short-circuit electric current per unit of device area ( $\text{A m}^{-2}$ )
$i_{cc}$	Closed-circuit electric current per unit of device area ( $\text{A m}^{-2}$ )
$r$	Electrical resistance of a $\mu\text{TEG}$ per unit of device area ( $\Omega \text{m}^{-2}$ )
$r_{load}$	Electrical resistance of the load per unit of device area ( $\Omega \text{m}^{-2}$ )

\*Corresponding Author: [davide.beretta@uzh.ch](mailto:davide.beretta@uzh.ch)

# 1 Introduction

Micro Thermoelectric Generators ( $\mu$ TEGs) are solid-state devices designed to convert heat into electrical energy through the Seebeck effect. [1] Traditional  $\mu$ TEGs consist of several thermocouples fabricated in electrical series and thermal parallel, between two electrically insulating substrates, such that a temperature difference between the substrates drives an electric current. Typically,  $\mu$ TEG are designed to operate under small temperature differences, around room temperature, where modest heat fluxes ensure that the hot reservoir never runs out. With theoretically infinite reservoirs,  $\mu$ TEGs are optimized to maximize the generated electrical power, with little regard for conversion efficiency. This optimization requires the thermal resistance of the device to match the thermal resistance of the device's coupling to the reservoirs — a condition known as thermal matching, typically resulting in thermocouples on the order of micrometers in length, hence the name micro-TEGs or  $\mu$ TEGs. [2, 3]  $\mu$ TEGs are particularly suited for low-power electronics applications, such as battery charging. Despite their potential, the design and optimization of these devices are often hindered by the complexity of simulating their performance, as the governing equations are multi-physics and non-linear, and cannot be solved analytically. This challenge forces researchers and engineers to develop custom code, which can be time-consuming and error-prone, especially for those without extensive programming experience. Alternatively, linearized models are often used, but these tend to overestimate the device's performance, by more than 10% in the application ranges of interest [2]. To address this gap, this work presents a user-friendly, open-source Python package based on a lumped-element model to simulate  $\mu$ TEGs. Building on the work of Beretta et al., [2] the package allows users to calculate key parameters such as power, conversion efficiency, open-circuit voltage, short-circuit current, and electrical resistance per unit of device area as functions of thermocouple length, device geometry, material properties and temperature difference. Featuring a simple and intuitive graphical interface, the package is accessible to both experienced users and those with limited programming experience for performing basic thermoelectric simulations. It is available via PIP, can be executed from the command line, and its full source code is hosted on GitHub for transparency and further customization. [4] By simplifying the simulation process, this Python package facilitates rapid prototyping and performance evaluation—an invaluable step before progressing to more advanced Finite Element Method (FEM) multi-physics simulations.

## 2 Model

The software is based on the non-linear model developed by Beretta et al., [2] solving the multi-physics

problem illustrated in Fig. 1 and described by the following system of non-linear equations:

$$\dot{q}_h = h_{r,h}(T_{r,h} - T_{s,h}) \quad (1)$$

$$\dot{q}_h = h_{s,h}(T_{s,h} - T_h) \quad (2)$$

$$\dot{q}_h = h_{pni}(T_h - T_c) + \dot{q}_{\pi,h} - \dot{q}_j/2 \quad (3)$$

$$\dot{q}_h = h_{pni}(T_h - T_c) + \dot{q}_{\pi,c} + \dot{q}_j/2 \quad (4)$$

$$\dot{q}_c = h_{s,c}(T_c - T_{s,c}) \quad (5)$$

$$\dot{q}_c = h_{r,c}(T_{s,c} - T_{r,c}) \quad (6)$$

In a typical  $\mu$ TEG,  $h_{s,h}$ ,  $h_{pni}$ , and  $h_{s,c}$  are determined solely by conduction, while  $h_{r,h}$  and  $h_{r,c}$  depend on the mechanism of thermal coupling and may include contributions from conduction, convection and radiation. The calculation of these coefficients is detailed in the Supporting Information of Beretta et al. [2] The thermal power transferred via the Peltier effect,  $\dot{q}_{\pi,h}$  and  $\dot{q}_{\pi,c}$ , as well as the power dissipated by the Joule effect,  $\dot{q}_j$ , are given by:

$$\dot{q}_{\pi,h} = i_{cc}n\pi p_n(T_h) \quad (7)$$

$$\dot{q}_{\pi,c} = i_{cc}n\pi p_n(T_c) \quad (8)$$

$$\dot{q}_j = nR_{pn}i_{cc}^2 \quad (9)$$

Here,  $i_{cc}$  represents the closed-circuit thermoelectric current per unit of device area, and is given by:

$$i_{cc} = \frac{f\alpha_{pn}(T_h - T_c)}{\rho_{pn}l(1 + m)} \quad (10)$$

where the fill fraction  $f = A_{pn}/A_{pni}$  is defined as the ratio between the combined area of the thermocouple legs  $A_{pn} = A_p + A_n$  to the total area occupied by a thermocouple unit  $A_{pni} = A_p + A_n + A_i$ . Once the system of Eqs. 1-6 is solved and the temperature profile of the device is determined, the software calculates the electric power  $p$ , efficiency of conversion  $\eta$ , device electrical resistance  $r$ , open circuit voltage  $v_{oc}$ , and short circuit current  $i_{sc}$  per unit of device area according to the following equations:

$$p = v_{load}i \quad (11)$$

$$\eta = \frac{p}{\dot{q}_h} \quad (12)$$

$$r = nR_{pn} \quad (13)$$

$$v_{oc} = n\alpha_{pn}(T_h - T_c) \quad (14)$$

$$i_{sc} = \frac{v_{oc}}{r} \quad (15)$$

The model is formulated as a parametric optimization problem. The software employs the finite difference method for numerical differentiation and uses SciPy's `fsolve` to solve the system of equations, i.e. to determine the temperature profile. The initial conditions provided by the user include the temperatures  $T_{r,h}$ ,  $T_{s,h}$ ,  $T_h$ ,  $T_c$ ,  $T_{s,c}$ , and  $T_{r,c}$ , and the heat fluxes  $\dot{q}_h$  and  $\dot{q}_c$ . Since `fsolve` is a local solver, the accuracy of the solution heavily depends on the initial guess. Poor initial conditions may result in convergence to local minima or failure to find a solution. To improve convergence, it is good practice to choose

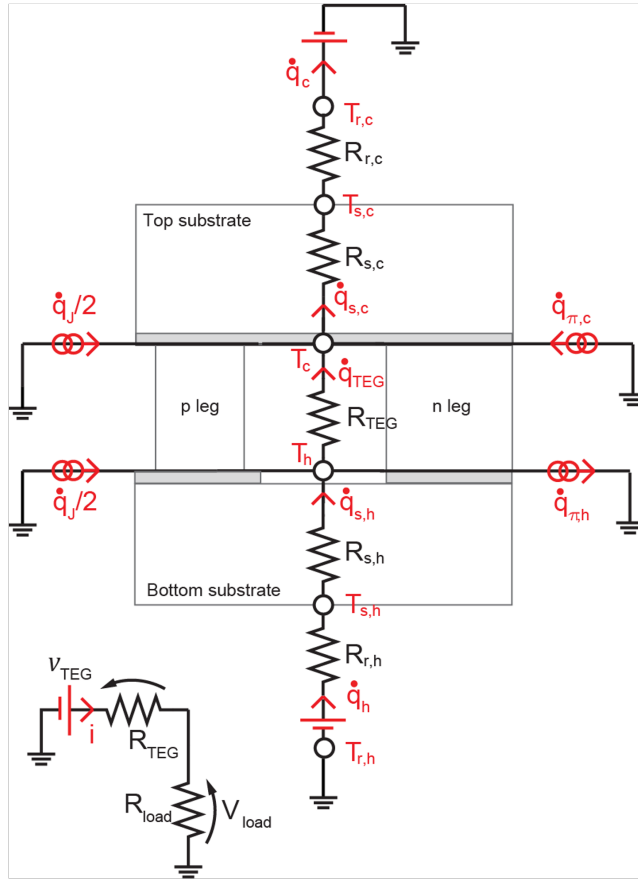

Figure 1: Electrical and thermal schematics of a  $\mu$ TEG consisting of a single thermocouple. The thermal model excludes the metallic interconnections, assuming their contribution is negligible, as discussed in the Supporting Information in Beretta et al. [2].

the initial conditions on the temperatures such that  $T_{r,h} \geq T_{s,h} \geq T_h \geq T_c \geq T_{s,c} \geq T_{s,c}$ , and to set the initial conditions on the heat flux such that  $\dot{q}_h = h_{r,h}(T_{r,h} - T_{s,h})$  and  $\dot{q}_c = h_{r,c}(T_{s,c} - T_{r,c})$ . Following these conventions improves solver robustness and ensures the results are physically meaningful.

### 3 User Interface

The software's main window consists of three primary frames: (i) the input frame, (ii) the simulation frame, and (iii) the status bar frame.

#### 3.1 Input Frame

The Input Frame allows users to define the model's parameters, which are grouped into three categories across two tabs. Each parameter is assigned a specific data type and is restricted to a predefined range. If a user enters an invalid value, the background of the corresponding entry field turns red, preventing the simulation from being executed. Please refer to [4] for an overview of the parameters available in the current release, including their descriptions, units, data types, default values, and valid ranges. The model's parameters can be reset to their default values, saved to, or

loaded from a .json file. Parameters are only loaded if the file and its contents pass a validation check for data type and range. A template file is available on the project's GitHub page for users to edit as needed. [4] All values are saved in SI units.

#### 3.2 Simulation Frame

The Simulation Frame is designed to run simulations and display results. It includes various buttons and toggles that allow users to manage the simulation process and customize the visualization of results. These controls enable actions such as starting or clearing simulations, saving results to a file, adjusting the display of specific metrics, and switching between linear and logarithmic scales for the axes. For a complete up-to-date list of all the options available to the user, please refer to [4].

#### 3.3 Status Bar Frame

The Status Bar Frame provides real-time updates and status information, including errors and warnings encountered during the simulation process, as well as messages regarding invalid inputs and I/O operations.

## 4 Representative Studies

This section presents the results of two simulations for two  $\mu$ TEG configurations, both utilizing thermoelectric materials with the following properties:  $\alpha_p = 100 \mu\text{V K}^{-1}$ ,  $\alpha_n = -100 \mu\text{V K}^{-1}$ ,  $\sigma_p = \sigma_n = 1 \times 10^3 \text{ S cm}^{-1}$ , and  $\kappa_p = \kappa_n = 1 \text{ W m}^{-1} \text{ K}^{-1}$ , yielding  $zT = \alpha^2 \sigma / \kappa \approx 0.3$ . The two configurations differ in their thermal coupling to the cold reservoir:

1. Simulation 1: The  $\mu$ TEG is thermally coupled to the hot reservoir via direct mechanical contact, characterized by  $h_{r,h} = 1 \times 10^6 \text{ W m}^{-2} \text{ K}^{-1}$ , and to the cold reservoir via heat exchangers, with  $h_{r,c} = 500 \text{ W m}^{-2} \text{ K}^{-1}$ . This configuration represents a standard  $\mu$ TEG design for low-power electronic applications, similar to those demonstrated by Böttner et al. [5].
2. Simulation 2: The  $\mu$ TEG is thermally coupled to both reservoirs via direct mechanical contact, with  $h_{r,h} = h_{r,c} = 1 \times 10^6 \text{ W m}^{-2} \text{ K}^{-1}$ . While less common, this design shows significant potential for energy harvesting in  $\mu$ TEGs integrated into semiconductor devices, as it requires shorter thermocouple lengths for thermal matching. This makes it especially suitable for compact and efficient implementations.

In both simulations,  $\kappa_i = 0.1 \text{ W m}^{-1} \text{ K}^{-1}$ , while the thermal transfer coefficients of the substrates are set to  $h_{s,h} = h_{s,c} = 1 \times 10^4 \text{ W m}^{-2} \text{ K}^{-1}$ , representing typical values for mm-thick thermally conducting ceramic substrates. Both devices consist of thermocouples with a cross-sectional area of  $100 \mu\text{m} \times 100 \mu\text{m}$  and a fill fraction of 50%. Simulations were conducted for thermocouple lengths ranging from  $1 \mu\text{m}$  to  $1 \text{ cm}$ , with  $T_h = 305 \text{ K}$  and  $T_c = 300 \text{ K}$  under condition of load-matching ( $m = 1$ ). Fig. 2 and Fig. 3 show the results for Simulation 1 and Simulation 2, respectively. The maximum power is achieved at thermocouple lengths that depend on the heat transfer coefficients. These lengths range from approximately  $1 \text{ mm}$  for poor coupling with heat exchangers (Simulation n.1) to about  $100 \mu\text{m}$  for optimal direct mechanical coupling (Simulation n.2). As expected, the efficiency, resistance, and open-circuit voltage per unit of device area increase monotonically with thermocouple length, while the short-circuit current per unit area decreases. Interestingly, if the substrate heat transfer coefficients were increased by one or two orders of magnitude, the optimal thermocouple length would shift to the nanoscale range, making nanoscale thermoelectric generators (nTEGs), which exhibit promising thermoelectric quantum properties [6], practically viable.

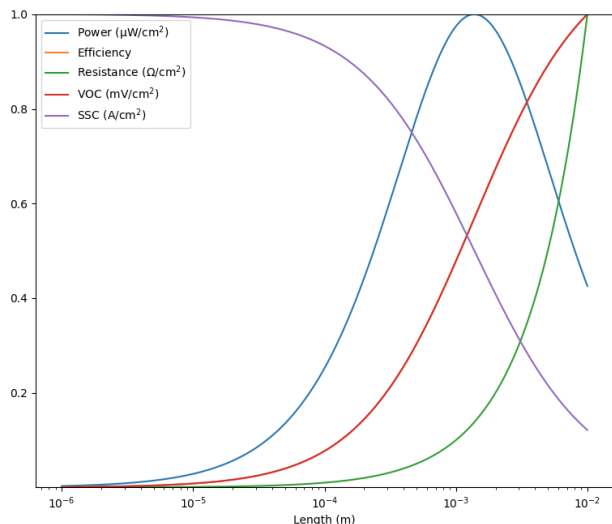

Figure 2: Normalized simulation results for a thermoelectric device thermally coupled to the hot reservoir via mechanical contact and to the cold reservoir via heat exchangers (Simulation n.1).

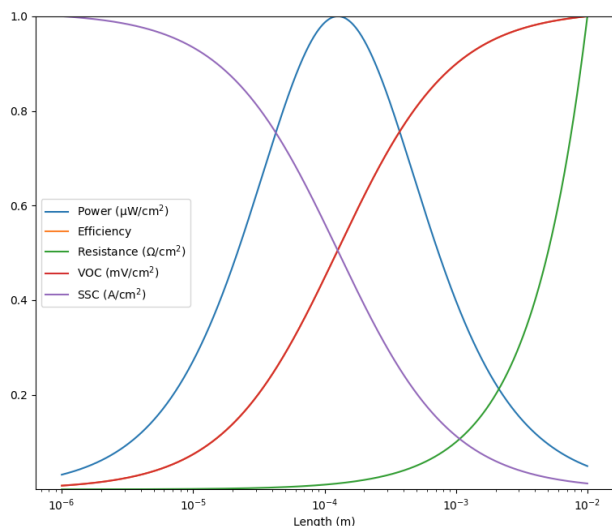

Figure 3: Normalized simulation results for a thermoelectric device thermally coupled to both the hot and cold reservoirs by mechanical contact (Simulation n.2).

## 5 Conclusions

This work presents an open-source Python package designed to provide a user-friendly tool for simulating micro thermoelectric generators. Built on the lumped element model by Beretta et al. [2], the package features an intuitive graphical user interface, enabling users of all experience levels to perform basic simulations. The package is available via PIP, executable from the command line, and its full source code is hosted on GitHub, ensuring transparency and allowing for further customization [4]. By simplifying the process of modeling thermoelectric systems, this Python package enables quick, efficient simulations, providing a foundation for

more complex analyses and supporting further development in thermoelectric energy conversion.

## A Useful Equations

### A.1 The Heat Transfer Coefficients

The heat transfer coefficients of the substrates and the thermocouples depend solely on thermal conduction and are given by:

$$h_{s,h} = \frac{\kappa_{s,h}}{l_{s,h}} \quad (16)$$

$$h_{pni} = \frac{\kappa_{pni}}{l} \quad (17)$$

$$h_{s,c} = \frac{\kappa_{s,c}}{l_{s,c}} \quad (18)$$

where  $k_{pni} = (\kappa_p A_p + \kappa_n A_n + \kappa_i A_i) / A_{pni}$  is the weighted average thermal conductivity of a thermocouple unit. On the other hand, the heat transfer coefficients of the reservoirs depend on the mechanism of thermal coupling and may include contributions from conduction, convection and radiation.

### A.2 The Heat Fluxes

The Peltier and Joule heat fluxes, as described in Eqs. 7 – 9, depend on the thermoelectric properties of the thermocouples, the device design, and the temperature. Using the Kelvin's relation, the Peltier coefficients can be expressed as  $\pi_{pn}(T_h) = \alpha_{pn} T_h$  and  $\pi_{pn}(T_c) = \alpha_{pn} T_c$ . Substituting Eq. 10 into Eqs. 7 – 9, the Peltier and Joule heat fluxes can be expressed as in Beretta et al. [2]:

$$\dot{q}_{\pi,h} = \frac{f \alpha_{pn}^2}{\rho_{pn}(1+m)l} T_h (T_h - T_c) \quad (19)$$

$$\dot{q}_{\pi,c} = \frac{f \alpha_{pn}^2}{\rho_{pn}(1+m)l} T_c (T_h - T_c) \quad (20)$$

$$\dot{q}_j = \frac{f \alpha_{pn}^2}{\rho_{pn}(1+m)2l} (T_h - T_c)^2 \quad (21)$$

### A.3 The Open Circuit Voltage

The thermoelectric voltage developed by one thermocouple is:

$$V_{pn} = \alpha_{pn} (T_h - T_c) \quad (22)$$

The open circuit voltage of a  $\mu$ TEG is given by the thermoelectric voltage developed by one thermocouple times the number of thermocouples  $N$  in the generator:

$$V_{oc} = N V_{pn} \quad (23)$$

The open circuit voltage per unit of device area is the thermoelectric voltage developed by one thermocouple  $V_{pn}$  times the number of thermocouples per unit of device area  $n$ :

$$v_{oc} = n V_{pn} \quad (24)$$

### A.4 The Electrical Resistance

In Beretta et al. [2], the electrical resistance of a thermocouple is defined as:

$$R_{pn} = \frac{\rho_p}{A_p} l + \frac{\rho_n}{A_n} l = \rho_{pn} \frac{l}{A_{pn}}, \quad (25)$$

where  $\rho_{pn} = (\rho_p/A_p + \rho_n/A_n) A_{pn}$  is the weighted average resistivity of the thermocouple. This formulation assumes an equivalent conductor with effective area  $A_p + A_n$  and length  $l$ . Alternatively, one might consider a different effective conductor with an average cross-sectional area of  $(A_p + A_n)/2$  and a length of  $2l$  (i.e. twice the thermocouple length). In this case, the effective resistivity would be determined by:

$$R_{pn} = \frac{\rho_p}{A_p} l + \frac{\rho_n}{A_n} l = \rho'_{pn} \frac{2l}{\frac{A_p + A_n}{2}} \quad (26)$$

which yields  $\rho'_{pn} = (\rho_p/A_p + \rho_n/A_n) A_{pn}/4$ , such that  $4\rho'_{pn} = \rho_{pn}$ . Only this alternative formulation ensures that  $\rho'_{pn} \rightarrow \rho_p$  when  $\rho_n = \rho_p$  and  $A_p = A_n$ . Regardless of whether one uses the original or the alternative definition of effective conductor, the underlying physics of the model remains unchanged. For the sake of consistency with the original work by Beretta et al. [2], this work makes use of the original definition.

The electrical resistance of a  $\mu$ TEG is the electrical resistance of one thermocouple  $R_{pn}$  times the number of thermocouples in the generator  $N$ :

$$R = N R_{pn} \quad (27)$$

The electrical resistance of a  $\mu$ TEG per unit of device area is the electrical resistance of one thermocouple  $R_{pn}$  times the number of thermocouples per unit of device area  $n$ :

$$r = n R_{pn} \quad (28)$$

### A.5 The Thermoelectric Current

The thermoelectric current generated by a single thermocouple is given by:

$$I_{pn} = \frac{V_{pn}}{R_{pn}} \quad (29)$$

The short circuit current  $I_{sc}$  generated by a  $\mu$ TEG is the ratio between the open circuit voltage  $V_{oc}$  and the device electrical resistance  $R$ . Since both  $V_{oc}$  and  $R$  scale linearly with the number of thermocouples  $N$ , the short circuit current of a  $\mu$ TEG is independent of the number of thermocouples. This can be shown as:

$$I_{sc} = \frac{V_{oc}}{R} = \frac{N V_{pn}}{N R_{pn}} = I_{pn} \quad (30)$$

Similarly, the closed circuit current  $I_{cc}$  generated by a  $\mu$ TEG is also independent of the number of thermocouples. It is expressed as:

$$I_{cc} = \frac{V_{oc}}{R + R_{load}} = \frac{V_{pn}}{R_{pn}} \cdot \frac{1}{1+m} \quad (31)$$

where  $m = R_{load}/R$  represents the load-to-device resistance ratio. For the closed circuit current per unit of device area  $i_{cc}$ , it is convenient to define the load resistance per unit of device area as  $r_{load} = nR_{load}$ . In fact, since the resistance of the device scales with the number of thermocouples, and thus with the device area, the load resistance can be conveniently chosen as a function of the device area. This leads to:

$$i_{cc} = \frac{v_{oc}}{r + r_{load}} = \frac{V_{pn}}{R_{pn}} \cdot \frac{1}{1 + m'} \quad (32)$$

where  $m' = r_{load}/r$ . Note that  $m' = m$ , ensuring consistency between the resistance ratios for the full device and the per-unit-area formulation.

## A.6 The Power

The power generated by a  $\mu$ TEG is given by:

$$P = V_{load}I_{cc} \quad (33)$$

where the voltage drop on the load is:

$$V_{load} = V_{oc} \cdot \frac{R_{load}}{R + R_{load}} = V_{oc} \cdot \frac{m}{1 + m} \quad (34)$$

By substituting Eq. 23 in Eq. 34, and then Eq. 34 and Eq. 31 in Eq. 33, the power can be expressed as:

$$P = \frac{V_{pn}^2}{R_{pn}} \cdot \frac{m}{(1 + m)^2} \quad (35)$$

Similarly, the power per unit of device area is given by:

$$p = v_{load}i_{cc} \quad (36)$$

where the voltage drop on the load per unit of device area is:

$$v_{load} = v_{oc} \cdot \frac{r_{load}}{r + r_{load}} = v_{oc} \cdot \frac{m'}{1 + m'} \quad (37)$$

By substituting Eq. 24 in Eq. 37, and then Eq. 37 and Eq. 32 in Eq. 36, the power per unit of device area can be expressed as:

$$p = \frac{nV_{pn}^2}{R_{pn}} \frac{m'}{(1 + m')^2} \quad (38)$$

Finally, it is convenient to express Eq. 38 in terms of material properties, device geometry, temperature conditions, and circuit design, yielding:

$$p = \frac{\alpha_{pn}^2}{\rho_{pn}} \cdot \frac{f}{l} \cdot \Delta T^2 \cdot \frac{m'}{(1 + m')^2} \quad (39)$$

## A.7 Optimal Conditions

The maximum power output of a  $\mu$ TEG is achieved under the conditions of load matching and thermal matching. The load matching condition involves maximizing Eq. 39 with respect to  $m$ . It is straightforward to show that the power is maximized when  $m = 1$ ,

meaning the load resistance should match the device resistance. On the other hand, the thermal matching condition is achieved by maximizing  $(T_h - T_c)$ . For the non-linear system of Eqs. 1–6, an analytical condition for thermal matching cannot be derived. However, Beretta et al. [2] demonstrated that, for the linearized model, the thermal matching condition corresponds to selecting a thermocouple length of  $l = k_{pmi}/h_{eq}$ , where  $h_{eq}^{-1} = h_{r,h}^{-1} + h_{s,h}^{-1} + h_{s,c}^{-1} + h_{r,c}^{-1}$  is the equivalent heat transfer coefficient. While this is not the exact optimal condition for the non-linear model, it provides a useful guideline for maximizing the temperature difference across the hot and cold ends of the thermocouples.

## Acknowledgments

None to report.

## References

- [1] D. Beretta, N. Neophytou, J. M. Hodges, M. G. Kanatzidis, D. Narducci, M. Gonzalez, M. Beekman, B. Balke, G. Cerretti, W. Tremel, A. Zevalkink, A. I. Hofmann, C. Müller, B. Dörfling, M. Campoy-Quiles, and M. Caironi. Thermoelectrics: From history, a window to the future. *Materials Science and Engineering: R: Reports*, 138:100501, 10 2019. doi:10.1016/j.mser.2018.09.001.
- [2] D. Beretta, A. Perego, G. Lanzani, and M. Caironi. Organic flexible thermoelectric generators: from modeling, a roadmap towards applications. *Sustainable Energy & Fuels*, 1(1):174–190, 00 2017. doi:10.1039/c6se00028b.
- [3] Y. Apertet, H. Ouerdane, C. Goupil, and Ph Lecoœur. Influence of thermal environment on optimal working conditions of thermoelectric generators. *Journal of Applied Physics*, 116(14):144901, 10 2014. doi:10.1063/1.4897350.
- [4] Davide Beretta. mu-teg-sim, July 2024. doi:10.5281/zenodo.12802052.
- [5] H. Bottner. Micropelt miniaturized thermoelectric devices: small size, high cooling power densities, short response time. In *ICT 2005. 24th International Conference on Thermoelectrics, 2005.*, pages 1–8. IEEE, 06 2005. doi:10.1109/ict.2005.1519873.
- [6] M. S. Dresselhaus, G. Chen, M. Y. Tang, R. G. Yang, H. Lee, D. Z. Wang, Z. F. Ren, J.-P. Fleurial, and P. Gogna. New Directions for Low-Dimensional Thermoelectric Materials. *Advanced Materials*, 19(8):1043–1053, 04 2007. doi:10.1002/adma.200600527.