

# SPICE-PIDE: A Methodology for Design and Optimization of Integrated Circuits

Jehan Taraporewalla<sup>1,2,†</sup>, Arun KP<sup>1,†</sup>, Sugata Ghosh<sup>1</sup>, Abhishek Agarwal<sup>1</sup>,  
Bijaydoot Basak<sup>1</sup>, and Dipankar Saha<sup>1,3</sup>

<sup>1</sup>Department of Electronics and Telecommunication Engineering, Indian Institute of Engineering Science and Technology Shibpur, Howrah-711103, India

<sup>2</sup>Department of Electrical Engineering, Indian Institute of Technology Delhi, New Delhi-110016, India

<sup>3</sup>Department of Electronics and Communication Engineering, Narula Institute of Technology, Agarpara, Kolkata-700109, India.

<sup>†</sup>J.T and A. KP contributed equally to work  
e-mail: dipsah\_etc@yahoo.co.in and pc.jehan@gmail.com

## Abstract

In application-specific designs, owing to the trade-off between power consumption and speed, optimization of various circuit parameters has become a challenging task. Several of the performance metrics, viz., energy efficiency, gain, performance, and noise immunity, are interrelated and difficult to tune. Such efforts may result in a great deal of manual iterations which in turn increase the computational overhead. Thus, it is important to develop a methodology that not only explores large design space but also reduces the computational time. In this work, we investigate the viability of using a SPICE and Python IDE (PIDE) interface to optimize integrated circuits. The SPICE simulations are carried out using 22 nm technology node with a nominal supply voltage of 0.8 V. The SPICE-PIDE optimizer, as delineated in this work, is able to provide the best solution sets considering various performance metrics and design complexities for 5 transistor level converters.

*Keywords:* SPICE-PIDE, average power, PDP, design optimization, level converter.

## 1 Introduction

Optimization of integrated circuits is a difficult task for the designer owing to the trade-offs among various parameters viz. supply voltage, gain, linearity, power consumption, output swing, noise, etc. [1–4]. In the manual approach, while designing any integrated circuit, the designer has to size each component individually, and that takes a long time [5–7]. Therefore, we require an accurate method which is compatible with industry standard EDA tools such as SPICE engine [3, 8].

The goal of this work is to examine the viability of Python IDE for design optimization via data analysis, parameter selection, and prioritization of efficient solutions [9]. In this work, we consider the 5 transistor level converter designs reported in [10] and employ SPICE-PIDE [9] in order to obtain optimal solutions with ultra-low power consumption. These 5 transistor ultra-low power level converters (as shown in Fig. 1) can work effectively in the near-threshold region with energy efficiency at par with other sub-threshold level

converters [11–14]. We carry out a detailed study that involves the exploration of design space and considers 1843968 cases in order to find a set of best solutions during the optimization of 5 transistor level converters.

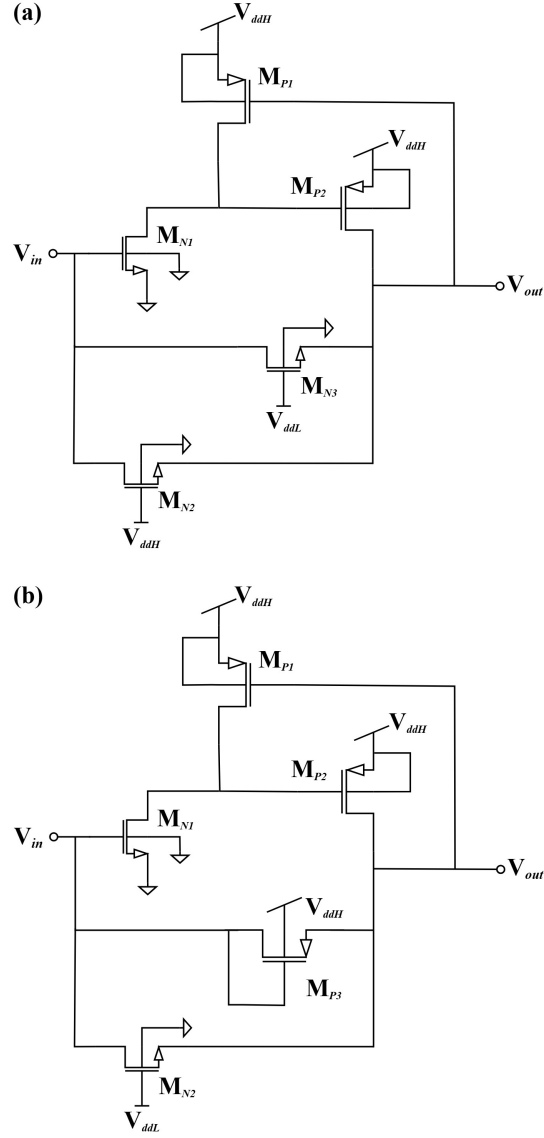

Figure 1: Architecture of 5 transistor level converters (a) NNPT and (b) PNPT with the transistor sizing of 40nm/40nm for  $M_{P2}$  and load of 5 fF. The  $V_{ddH}$  and  $V_{ddL}$  values are 0.8 V and 0.6 V respectively [10].

## 2 Methodology

In order to predict the behaviour of the 5 transistor level converters in state of the art technology node, we employ the metal gate, high-K, and strained-Si High Performance 22 nm Predictive Technology Model (PTM) version: 4.0 level: 54 [15]. All simulations are done using SPICE with 22 nm technology node [16].

---

```
Code for exploring the design space
```

---

```
import subprocess, Itspice, pandas, operator, and Itspy3meas

Vin = 0.6 V, VddL = 0.6 V, and VddH = 0.8 V

Design metric: [ VSwing, Avg. Power, PDP ]

For i in range(40,840,50):

    Design variables:[ LMP1, LMP2, LMN1, LMN2, LMN3 ]

        For i in range(40,1720,120):

            Design variables:[ WMP1, WMN1, WMN2, WMN3 ]

Netlist of 5 transistor level shifter

#meas statements for Avg. Power
.meas PoutH AVG -V(VddH)*I
.meas PoutL AVG -V(VddL)*I

#meas statements for Voltage Swing
.meas trans Vout,max MAX V(Vout)
.meas trans Vout,min MIN V(Vout)

#meas statements for Delay
Tran tplh TRIG V(Vin) = (Vin/2) RISE=1 TARG V(Vout) = Vout,min + (VSwing/2)
RISE=1
Tran tphl TRIG V(Vin) = (Vin/2) FALL=1 TARG V(Vout) = Vout,min + (VSwing/2)
FALL=1
.meas Td PARAM MAX(tplh,tphl)

sp.call(Itspice, Netlist)
Itspy3meas.LogGetClass(meas variables)

if VSwing ≥ 0.78 : [Designvariables, VSwing, Avg. Power, PDP].append

end loop

list(zip(Design variables, Design metric))
```

Figure 2: Pseudo code for optimization of NNPT LC using SPICE-PIDE.

---

```

Code for exploring the design space

```

---

```

import subprocess, lts spice, pandas, operator, and lts py3meas

Vin = 0.6 V, VddL = 0.6 V, and VddH = 0.8 V

Design metric: [ VSwing, Avg. Power, PDP ]

For i in range(40,840,50):

Design variables:[ LMP1, LMP2, LMN1, LMN2, LMP3 ]

    For i in range(40,1720,120):

        Design variables:[ WMP1, WMN1, WMN2, WMP3 ]

Netlist of 5 transistor level shifter

#meas statements for Avg. Power
.meas PoutH AVG -V(VddH)*I
.meas PoutL AVG -V(VddL)*I

#meas statements for Voltage Swing
.meas trans Vout,max MAX V(Vout)
.meas trans Vout,min MIN V(Vout)

#meas statements for Delay
Tran tplh TRIG V(Vin)=(Vin/2) RISE=1 TARG V(Vout)=Vout,min+(VSwing/2)
RISE=1
Tran tphl TRIG V(Vin)=(Vin/2) FALL=1 TARG V(Vout)=Vout,min+(VSwing/2)
FALL=1
.meas Td PARAM MAX(tplh,tphl)

sp.call(lts spice, Netlist)
lts py3meas.LogGetClass(meas variables)

if VSwing ≥ 0.78 : [Designvariables, VSwing, Avg. Power, PDP].append

end loop

list(zip(Design variables, Design metric)

```

Figure 3: Pseudo code for optimization of PNPT LC using SPICE-PIDE.

The default NMOS and PMOS transistors as per our recipe for carrying out the simulations have length and width values:  $L_{\text{NMOS}} = L_{\text{PMOS}} = 40$  nm,  $W_{\text{NMOS}} = 200$  nm, and  $W_{\text{PMOS}} = 500$  nm. Moreover, the nominal supply voltage reported in High Performance 22 nm Predictive Technology Model is 0.8 V with the reported threshold voltages of 0.503 V & 0.460 V, for NMOS and PMOS transistors [15, 17]. A 10 ns rise time / fall time is taken for the input pulse and the contribution of both supplies ( $V_{\text{ddL}}$  and  $V_{\text{ddH}}$ ) is

considered while calculating the average power consumption. Besides, a 5 fF load capacitance ( $C_L$ ) is used for all the simulations, carried out at a frequency of 10 MHz.

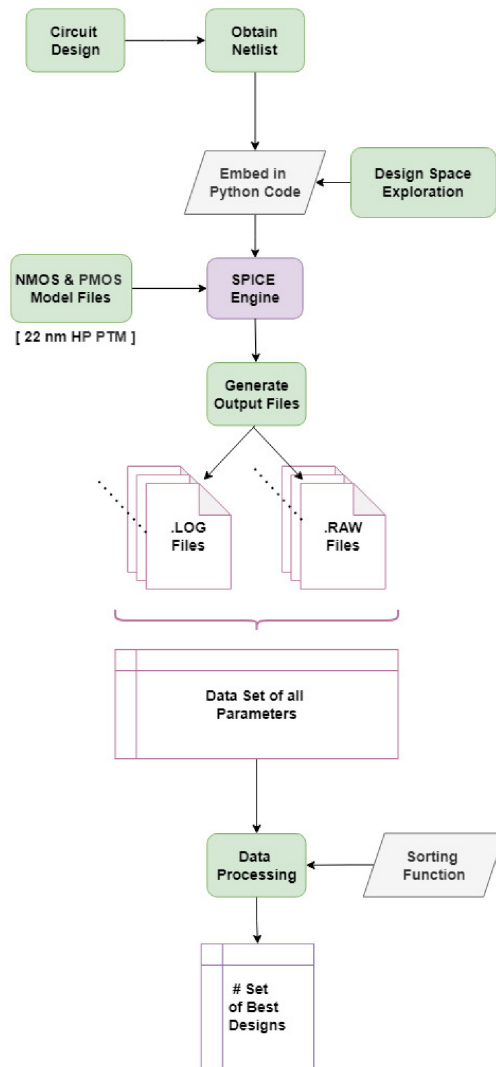

Figure 4: Flow diagram illustrating the design optimization of 5 transistor level converters.

The SPICE-PIDE optimizer as discussed in [9], heuristically explores the design space and lists all possible solutions for any circuit design. The codes

for exploring the design space of NNPT and PNPT level converters are delineated in Fig. 2 and 3, respectively. It utilizes data processing code to find out the best solution set considering various key performance parameters. The Fig. 4 shows the flow diagram depicting integration between SPICE and PIDE utilized for design optimization of level converters. It emphasises on the various steps taken by SPICE-PIDE optimizer to obtain the set of best solutions.

### 3 Results

Here, the SPICE-PIDE optimizer is employed to explore umpteen possible solutions for ultra low power signal conversion utilizing the SPICE engine [16] in conjunction with Spyder (a well known Python IDE) [18]. The combination of parameters used to investigate the possible solutions are as follows:

- Input voltage,  $V_{in} = 0.6$  V
- Supply voltage, High,  $V_{ddH} = 0.8$  V
- Supply voltage, Low,  $V_{ddL} = 0.6$  V
- $W_{P2} = 40$  nm (is not varied)
- Transistor length values ( $L_i$ ) are varied across 16 values from 40 nm to 840 nm
- All other transistor width values ( $W_i$ ) are varied across 14 values from 40 nm to 1720 nm

To evaluate and rank the various solutions, several performance metrics e.g. output voltage swing ( $V_{Swing}$ ), average power dissipation ( $P_{Avg.}$ , considering  $V_{ddH}$  and  $V_{ddL}$ ), and Power Delay Product (PDP) are used.

It is to be noted that the design space for NNPT level converter considers the combination of two gate voltages viz.  $V_{G\_N2} = V_{ddH}$  &  $V_{G\_N3} = V_{ddL}$  and  $V_{G\_N2} = V_{ddL}$  &  $V_{G\_N3} = V_{ddH}$  respectively during evaluation. The tables (Table I & Table II) illustrate the best solution sets considering the performance parameters as discussed earlier. It is evident from the results, as listed in Table I, that the average power consumption is significantly reduced (26.5866 nW), compared to 32.5704 nW as reported in [10] (while

maintaining complete output voltage swing). Considering interfacing with other digital blocks via long interconnects, such a robust and energy efficient level converter design can be very useful.

Table 1: Solution set ranked based on  $P_{\text{Avg.}}$  while optimizing LC NNPT

Solution Set		Gate Voltage Combination	$P_{\text{Avg.}}$ (nW)	$T_{\text{dmax}}$ (ns)	$V_{\text{out\_low}}$ (nV)	$V_{\text{out\_high}}$ (mV)
$L_i=90\text{nm}$ $W_{N1}=40\text{nm}$ $W_{N3}=160\text{nm}$	$W_{P1}=160\text{nm}$ $W_{N2}=640\text{nm}$	$V_{G\_N2} = V_{\text{ddH}}$ $V_{G\_N3} = V_{\text{ddL}}$	26.5866	0.624	408.923	799.984
$L_i=90\text{nm}$ $W_{N1}=40\text{nm}$ $W_{N3}=640\text{nm}$	$W_{P1}=160\text{nm}$ $W_{N2}=160\text{nm}$	$V_{G\_N2} = V_{\text{ddL}}$ $V_{G\_N3} = V_{\text{ddH}}$	26.5866	0.624	408.924	799.984
$L_i=140\text{nm}$ $W_{N1}=40\text{nm}$ $W_{N3}=760\text{nm}$	$W_{P1}=40\text{nm}$ $W_{N2}=40\text{nm}$	$V_{G\_N2} = V_{\text{ddL}}$ $V_{G\_N3} = V_{\text{ddH}}$	26.5892	0.763	1988.65	799.981
$L_i=90\text{nm}$ $W_{N1}=40\text{nm}$ $W_{N3}=400\text{nm}$	$W_{P1}=40\text{nm}$ $W_{N2}=160\text{nm}$	$V_{G\_N2} = V_{\text{ddL}}$ $V_{G\_N3} = V_{\text{ddH}}$	26.5893	0.697	1026.84	799.99
$L_i=90\text{nm}$ $W_{N1}=40\text{nm}$ $W_{N3}=160\text{nm}$	$W_{P1}=40\text{nm}$ $W_{N2}=400\text{nm}$	$V_{G\_N2} = V_{\text{ddH}}$ $V_{G\_N3} = V_{\text{ddL}}$	26.5893	0.697	1026.84	799.99
$L_i=140\text{nm}$ $W_{N1}=40\text{nm}$ $W_{N3}=40\text{nm}$	$W_{P1}=40\text{nm}$ $W_{N2}=760\text{nm}$	$V_{G\_N2} = V_{\text{ddH}}$ $V_{G\_N3} = V_{\text{ddL}}$	26.6465	0.763	1979.61	799.981
$L_i=90\text{nm}$ $W_{N1}=40\text{nm}$ $W_{N3}=40\text{nm}$	$W_{P1}=40\text{nm}$ $W_{N2}=640\text{nm}$	$V_{G\_N2} = V_{\text{ddH}}$ $V_{G\_N3} = V_{\text{ddL}}$	26.7466	0.647	503.803	799.925
$L_i=90\text{nm}$ $W_{N1}=40\text{nm}$ $W_{N3}=520\text{nm}$	$W_{P1}=160\text{nm}$ $W_{N2}=40\text{nm}$	$V_{G\_N2} = V_{\text{ddL}}$ $V_{G\_N3} = V_{\text{ddH}}$	26.7486	0.641	1281.01	799.942

Howbeit, if we prioritize the performance and consider the metric PDP, then the results presented in Table II exhibit a little improvement (i.e.  $8.528 \times 10^{-18}$  J as compared to  $9.412 \times 10^{-18}$  J as reported in [10]). Moreover, the aforementioned solutions do not significantly increase the silicon area overhead.



Table 2: Solution set ranked based on PDP while optimizing LC NNPT

Solution Set		Gate Voltage Combination	PDP (aJ)	$T_{dmax}$ (ns)	$V_{out\_low}$ (nV)	$V_{out\_high}$ (mV)
$L_i=40nm$ $W_{N1}=160nm$ $W_{N3}=40nm$	$W_{P1}=40nm$ $W_{N2}=1000nm$	$V_{G\_N2} = V_{ddH}$ $V_{G\_N3} = V_{ddL}$	8.528	0.254	177.783	799.967
$L_i=40nm$ $W_{N1}=160nm$ $W_{N3}=1000nm$	$W_{P1}=40nm$ $W_{N2}=40nm$	$V_{G\_N2} = V_{ddL}$ $V_{G\_N3} = V_{ddH}$	8.594	0.254	177.779	799.967
$L_i=40nm$ $W_{N1}=160nm$ $W_{N3}=40nm$	$W_{P1}=40nm$ $W_{N2}=1480nm$	$V_{G\_N2} = V_{ddH}$ $V_{G\_N3} = V_{ddL}$	8.692	0.249	176.226	799.949
$L_i=40nm$ $W_{N1}=160nm$ $W_{N3}=1480nm$	$W_{P1}=40nm$ $W_{N2}=40nm$	$V_{G\_N2} = V_{ddL}$ $V_{G\_N3} = V_{ddH}$	8.692	0.249	176.226	799.949
$L_i=40nm$ $W_{N1}=400nm$ $W_{N3}=40nm$	$W_{P1}=160nm$ $W_{N2}=1120nm$	$V_{G\_N2} = V_{ddH}$ $V_{G\_N3} = V_{ddL}$	8.725	0.254	188.121	799.962
$L_i=40nm$ $W_{N1}=160nm$ $W_{N3}=160nm$	$W_{P1}=40nm$ $W_{N2}=1480nm$	$V_{G\_N2} = V_{ddH}$ $V_{G\_N3} = V_{ddL}$	8.832	0.251	175.812	799.951

As listed in Table III & Table IV, the solutions exhibit improved average power consumption (36.5228 nW) and PDP ( $19.98 \times 10^{-18}$  J) which are  $\sim 16.6\%$  and  $\sim 5.5\%$  improvement respectively compared to that of the PNPT level converter described in [10]. Moreover, the PNPT level converter presented here demonstrates a complete restoration of the output voltage, though with a slightly larger silicon area.

Table 3: Solution set ranked based on  $P_{Avg.}$  while optimizing LC PNPT

<b>Solution Set</b>	<b><math>P_{Avg.}</math> (nW)</b>	<b><math>T_{dmax}</math> (ns)</b>	<b>PDP (aJ)</b>	<b><math>V_{out\_low}</math> (nV)</b>	<b><math>V_{out\_high}</math> (mV)</b>
$L_i=90nm$ $W_{P1}=40nm$ $W_{N1}=40nm$ $W_{N2}=760nm$ $W_{P3}=40nm$	36.5228	1.086	39.663	346.467	799.991
$L_i=140nm$ $W_{P1}=40nm$ $W_{N1}=40nm$ $W_{N2}=1000nm$ $W_{P3}=160nm$	36.5776	1.859	67.997	525.352	799.956
$L_i=190nm$ $W_{P1}=40nm$ $W_{N1}=40nm$ $W_{N2}=1000nm$ $W_{P3}=40nm$	37.2161	2.555	95.087	1605.65	800.047
$L_i=240nm$ $W_{P1}=40nm$ $W_{N1}=40nm$ $W_{N2}=1480nm$ $W_{P3}=40nm$	37.2264	3.291	122.512	2583.5	799.956
$L_i=190nm$ $W_{P1}=40nm$ $W_{N1}=40nm$ $W_{N2}=1240nm$ $W_{P3}=40nm$	37.3237	2.529	94.391	2147.98	799.988
$L_i=240nm$ $W_{P1}=40nm$ $W_{N1}=40nm$ $W_{N2}=1000nm$ $W_{P3}=40nm$	37.5053	3.272	122.714	1735.81	800.003
$L_i=40nm$ $W_{P1}=40nm$ $W_{N1}=760nm$ $W_{N2}=640nm$ $W_{P3}=40nm$	37.76	1.093	47.271	812.5	799.992

Table 4: Solution set ranked based on PDP while optimizing LC PNPT

<b>Solution Set</b>	<b><math>P_{Avg.}</math> (nW)</b>	<b><math>T_{dmax}</math> (ns)</b>	<b>PDP (aJ)</b>	<b><math>V_{out\_low}</math> (nV)</b>	<b><math>V_{out\_high}</math> (mV)</b>
$L_i=40nm$ $W_{P1}=40nm$ $W_{N1}=760nm$ $W_{N2}=880nm$ $W_{P3}=40nm$	47.4606	0.421	19.980	919.093	799.993
$L_i=40nm$ $W_{P1}=40nm$ $W_{N1}=640nm$ $W_{N2}=880nm$ $W_{P3}=40nm$	47.4487	0.432	20.497	80.336	799.991
$L_i=40nm$ $W_{P1}=40nm$ $W_{N1}=520nm$ $W_{N2}=640nm$ $W_{P3}=40nm$	46.1263	0.445	20.526	80.155	799.976
$L_i=40nm$ $W_{P1}=40nm$ $W_{N1}=520nm$ $W_{N2}=880nm$ $W_{P3}=40nm$	46.2314	0.445	20.572	76.848	799.989
$L_i=40nm$ $W_{P1}=40nm$ $W_{N1}=880nm$ $W_{N2}=880nm$ $W_{P3}=40nm$	49.8017	0.414	20.617	83.068	799.989
$L_i=40nm$ $W_{P1}=40nm$ $W_{N1}=760nm$ $W_{N2}=1000nm$ $W_{P3}=40nm$	49.1144	0.422	20.726	411.976	799.989
$L_i=40nm$ $W_{P1}=40nm$ $W_{N1}=760nm$ $W_{N2}=640nm$ $W_{P3}=40nm$	49.565	0.419	20.767	82.857	799.988
$L_i=40nm$ $W_{P1}=40nm$ $W_{N1}=640nm$ $W_{N2}=1000nm$ $W_{P3}=40nm$	48.3256	0.433	20.924	82.184	799.988

## 4 Conclusion

In this paper, we employ SPICE-PIDE to optimize integrated circuits that operate with dual supply voltages. We find that the SPICE-PIDE optimizer can provide the solution sets considering metrics like avg. power, PDP, etc. for any circuit without increasing the computational load significantly. Besides, the most efficient solutions, as shown in Table I & Table II, can be utilized for the purpose of designing ultra-low power systems with improved performance.

## Acknowledgements

Arun KP thanks the department of Electronics and Telecommunication Engineering, Indian Institute of Engineering Science and Technology, Shibpur, India, for all the facilities and resources.

## References

- [1] B. Moradi, “Multi-objective mobile robot path planning problem through learnable evolution model,” *Journal of Experimental & Theoretical Artificial Intelligence*, vol. 31, no. 2, pp. 325-348, 2019.
- [2] B. Razavi, “Design of Analog CMOS Integrated Circuits,” 1st ed. McGraw-Hill, 2001.
- [3] S. Devi et al., “Automated design of analog circuits using machine learning techniques,” *25th International Symposium on VLSI Design and Test*, Sept., 2021.
- [4] K. Settaluri et al., “Automated design of analog circuits using reinforcement learning,” *IEEE Transactions on Computer-Aided Design of Integrated Circuits and Systems*, vol. 41, no. 9, pp. 2794-2807, 2021.
- [5] . G. Huang et al., “Machine Learning for Electronic Design Automation: A Survey,” *ACM Trans. Des. Autom. Electron. Syst.*, vol. 26, no. 5, article 40, pp. 1-46, 2021.

- [6] D. Saha et al., “Row based dual vdd assignment, for a level converter free csa design and its near-threshold operation,” *Advances in Electrical Engineering*, July, 2014.
- [7] S. Mukherjee et al., “A 4-bit Asynchronous Binary Search ADC for Low Power, High Speed Applications,” *International Symposium on Electronic System Design*, Dec., 2012.
- [8] G. Wolfe and R. Vemuri, “Extraction and use of neural network models in automated synthesis of operational amplifiers,” *IEEE Transactions on Computer-Aided Design of Integrated Circuits and Systems*, vol. 22, no. 2, pp. 198-212, 2003.
- [9] S. Ghosh et al., “An Accurate SPICE-PIDE Interface based Design Optimization Method for Integrated Circuits,” U.G. thesis, Indian Institute of Engineering Science and Technology, Shibpur, West Bengal, India, 2022.
- [10] K. Arun et al., “Transistor Size Optimized Ultra-low Power NNPT and PNPT Level Converter Designs,” *7th International Conference on Electronics, Materials Engineering & Nano-Technology (IEMENTech)*, pp. 1-6, 2023.
- [11] S. Kesharani et al., “Single Threshold TSO Level Converters for Ultra-Low Power Digital Designs,” *IEEE 19th India Council International Conference (INDICON)*, Nov., 2022.
- [12] K. N. Jayaraman and V. Agrawal, “A four transistor level converter for dual-voltage low-power design,” *Journal of Low Power Electronics*, vol. 10, no. 4, pp. 617–628, 2014.
- [13] S. R. Hosseini et al., “A Low-Power Subthreshold to Above-Threshold Voltage Level Shifter,” *IEEE Trans. Circuits Syst. II*, vol. 61, no. 10, pp. 753-757, 2014.
- [14] H. Shao and C. Y. Tsui, “A robust, input voltage adaptive and low energy consumption level converter for sub-threshold logic,” *33rd European Solid-State Circuits Conference*, Sept., 2007.
- [15] W. Zhao and Y. Cao, “New Generation of Predictive Technology Model for Sub-45nm Design Exploration,” *International Symposium on Quality Electronic Design (ISQED)*, March, 2006.

- [16] LTspice version 17.0.34, Analog Devices Corporation, [Online] available at: <https://www.analog.com/en/resources/design-tools-and-calculators/ltspice-simulator.html>
- [17] Predictive Technology Model, NIMO ASU, [Online] available at: <https://ptm.asu.edu/>
- [18] P. Raybaut, “Spyder-documentation,” Available online at: [python-hosted.org](https://python-hosted.org), 2009 [Online] available at: <https://www.spyder-ide.org/>